

Initial Environmental Examination

Project Number: 53277 - 002
February 2021

India: Assam Skill University Project Sub-Project: Construction of Boundary Wall of University Campus

Prepared by the Government of Assam for the Asian Development Bank

This initial environmental examination is a document of the borrower. The views expressed herein do not necessarily represent those of ADB's Board of Directors, Management, or staff, and may be preliminary in nature.

In preparing any country program or strategy, financing any project, or by making any designation of or reference to a particular territory or geographic area in this document, the Asian Development Bank does not intend to make any judgments as to the legal or other status of any territory or area.



GOVT. OF ASSAM
ASSAM SKILL DEVELOPMENT MISSION
KATABARI, DPS ROAD, NH-37
GARCHUK:: GUWAHATI-781035

No. ASDM- 49/2017/486

Dated 11th February 2021

To

The Director, SAHS
South Asia Department,
Human and Social Development Division
Asian Development Bank,
Mandaluyong, Metro Manila, Philippines

Subject: Endorsing of IEE Report for Assam Skill University (ASU) Project - Boundary wall Construction

Sir,

With reference to the letter received on 11-02-2021 via email from ADB on IEE Report for Assam Skill University (ASU) Project- Boundary wall Construction. IA- Assam Skill Development Mission is endorsing the ADB approved IEE Report for Assam Skill University Project for Boundary Construction (Project No. 53277).

Assam Skill Development Mission also, request you to kindly allow to publish the IEE report on the website www.asdm.assam.gov.in.

Yours Faithfully

(Anand Prakash Tiwari, IPS)
Mission Director
Assam Skill Development Mission
Guwahati-781035

Memo No ASDM- 49/2017/486-A

Dated 11/02/2021

Copy to:

1. PS to Principal Secretary, Skill, Employment and Entrepreneurship Department for kind appraisal to Principal Secretary.
2. Office Copy

/

(Anand Prakash Tiwari, IPS)
Mission Director
Assam Skill Development Mission
Guwahati-781035

ABBREVIATIONS

ADB	-	Asian Development Bank
ASDM	-	Assam Skill Development Mission
ASI	-	Archaeological Survey of India
ASU	-	Assam Skill University
CPCB	-	Central Pollution Control Board
EA	-	Executive Agency
EIA	-	environmental impact assessment
EMP	-	environmental management plan
GoA	-	Government of Assam
Gol	-	Government of India
GRC	-	grievance redress committee
GRM	-	grievance redress mechanism
IEE	-	initial environmental examination
IA	-	implementing agency
MOEFCC	-	Ministry of Environment, Forests and Climate Change
PMC	-	project management consultants
PMU	-	project management unit
PSC	-	project steering committee
PUC	-	Pollution under Control
PWD	-	Public Works Department
REA	-	rapid environmental assessment
SEIAA	-	State Environment Impact Assessment Authority
SEED	-	Skill, Employment and Entrepreneurship Department
SPS	-	Safeguard Policy Statement

CURRENCY EQUIVALENTS

(As of 23 January 2021)

Currency unit – Indian rupee (Rs)

Rs1.00 = \$0.0136986

\$1.00 = Rs 73.0

WEIGHTS AND MEASURES

μg	–	microgram
dB(A)	–	weighted decibel
km	–	kilometer
km^2	–	square kilometer
m	–	meter
m^2	–	square meter

TABLE OF CONTENTS

EXECUTIVE SUMMARY	iv
I. INTRODUCTION	1
A. Background	1
B. Compliance with India's Environmental Regulatory Framework	2
C. Asian Development Bank's Environmental Safeguard Policy Principles	4
D. Review and Approval Procedure	4
E. Report Structure	5
II. DESCRIPTION OF THE PROJECT COMPONENTS	6
A. Components of the ASU Project	6
B. Executing and Implementing Agencies	12
C. Implementation Schedule	12
III. DESCRIPTION OF THE EXISTING ENVIRONMENT for ASU Site	13
A. Environmental Profile	13
B. Ecological Resources	19
C. Economic Resources/Industries	24
D. Social and Cultural Resources	26
IV. ENVIRONMENTAL IMPACT AND MITIGATION MEASURES	27
A. Environmental Impacts	27
B. Location Impacts	27
C. Impacts during Design and Pre-Construction Phase	27
D. Impacts during Construction Phase	27
E. Environmental Impacts during Operation Phase	29
F. Description of Planned Mitigation Measures	30
G. Land Aquisition and Resettlement	37
V. ANALYSIS OF ALTERNATIVES	40
VI. ENVIRONMENT MANAGEMENT PLAN (EMP)	381
A. Institutional Arrangements for Project Implementation	39
B. Responsibility for updating IEE during Pre-Construction and Construction	41
C. Environmental Monitoring Plan	59
D. Capacity Building	62
E. Environmental Budget	62
F. Environmental Monitoring and Reporting	63
VII. PUBLIC CONSULTATION AND INFORMATION DISCLOSURE	64
A. Process For Consultations Followed	64
B. Future Consultation And Information Disclosure	69
C. Grievance Redress Mechanism	69
D. Composition and functions of GRC	70
VIII. FINDINGS AND RECOMMENDATIONS	72

IX. CONCLUSIONS

73

LIST OF ANNEXURES

Annexure-1: MoEFCC Notification on EXEMPTION OF environmental clearance for educational institutions	74
Annexure-2: Rapid Environmental Assessment (REA) Checklist	84
Annexure-3: LAND Records Certified by the Revenue Department Officials Showing GoA Ownership	91
Annexure-4: Sample Traffic Management Plan	94
Annexure-5: Photographs and Attendance Sheets of consultations	100

LIST OF TABLES

Table-1: Environmental Regulatory Compliance	3
Table-2: Description of the ASU Boundary Wall Components	8
Table-3: Soil Quality Data for Sub-Project Region	15
Table-4: Brahmaputra River Water quality in Sub-Project Region	16
Table-5: Different Categories of Forests Darrang District	19
Table-6: Common Tree Species around ASU Site	20
Table-7: Protected Areas in Assam	23
Table-8: Details of Existing Micro and Small Enterprises and Artisan Units in Darrang District	24
Table-9: Land Use Pattern of Darrang District	25
Table-10: Summary of Environmental Impacts and Planned Mitigation Measures	31
Table-11: Pre-Construction Phase Environmental Management Plan for Boundary Wall Construction	42
Table-12: Construction Phase Environmental Management Plan for Boundary Wall Construction	48
Table-13: Operation Phase Environmental Management Plan for Boundary Wall Construction	57
Table-14: Environmental Monitoring Plan for Boundary Wall Construction for Preconstruction and Construction Phases	60
Table-15: Site- and Activity-Specific Plans/Programs as EMP	61
Table-16: Environmental Management and Monitoring costs (INR)	62
Table-17: Dates and Stakeholders Consulted	65
Table-18: Views, Comments, and Suggestions of Stakeholders at Project Site and Considerations in Sub-Project Design	66
Table-19: Summary of Stake Holder Consultations at Institutional Level	67

LIST OF FIGURES

Figure-1: Location of ASU site	6
Figure-2: Location of ASU Site.....	7
Figure-3: Plan and Elevations of Boundary Wall	9
Figure-4: Monthwise Temperature variation at Mangaldoi	14
Figure-5: Rainfall Data for Mangaldoi.....	14
Figure-6: Hydrogeology Map for Darrang District	18
Figure-7: Protected Areas of Assam	24
Figure-8: Project implementation arrangement for safeguard compliance	41
Figure-9: Grievance Redress Mechanism (ASU Project).....	71

EXECUTIVE SUMMARY

1. The objective of the Assam Skill University Project is to strengthen industry-aligned and flexible skills education and training system in Assam by developing management and operating systems, business models, faculty development and management systems for Assam Skill University (ASU); developing environmentally sustainable and climate resilient ASU campus and facilities; designing and delivering industry-aligned and flexible skills education and training programs; strengthening engagement in industry-relevant applied research and development; and enhancing international and regional cooperation in skills education and training. The Skill, Employment and Entrepreneurship Department (SEED) of the Government of Assam (GoA) will be the executing agency (EA) and Assam Skill Development Mission (ASDM) will be the implementing agency (IA) of the project. ASDM has established a project management unit (PMU) to carry out day-to-day project management activities.

2. In order to achieve the above-mentioned outputs; it is proposed to support design and construction of a new green field ASU on 100 acre land. The site for ASU has been finalized near Mangaldoi town of Darrang district. The site is about 73 km from Guwahati. The ASU will be comprised of: (a) school of manufacturing and construction; (b) school of management and finance; (c) school of agriculture and food technology; (d) school of technology; (e) school of sustainability; (f) school of mobility; (g) school of design and creativity; (h) school of tourism, hospitality and wellness; (i) school of healthcare; (j) school of entrepreneurship and innovation; (k) school of life skills and languages; (l) school of lifelong learning; (m) school of faculty and curriculum development; and (n) school for persons with disabilities. The built-up area of the ASU will be around 150,000 m². The total cost of project is estimated to be US\$ 140 million.

3. The ASU project site is an unencumbered land owned by the government. The project is categorized as 'B' for environment. The boundary wall construction component of ASU is also category 'B' for environment. Accordingly, to comply with the Asian Development Bank (ADB)'s Safeguard Policy Statement (SPS, 2009), this initial environmental examination (IEE) report has been prepared.

4. For ease of implementation, ASU campus development has been divided into various components. These components, termed as subprojects, are being designed and finalized. The first ASU component to be implemented is boundary wall construction to improve site security. Total length of boundary wall to be constructed has been estimated approximately 3 km. This IEE report has been prepared for boundary wall construction.

5. The boundary wall design has been finalized after topographic survey and other factors such as intense rainfall and earthquake zone V coefficient. The boundary wall works will include brick work, plaster, cement concrete coping at top of column. Masonry cut outs have been provided in each panel for mitigation of wind pressure. To provide strength to the boundary wall columns have been provided at each 3.83m.

6. This **IEE** report provides details about the boundary wall to be constructed (at the outer periphery of ASU plot) and associated potential environmental impacts of the boundary wall civil works, and suggests ways of mitigating and addressing these impacts.¹ In the

¹Local stakeholders were involved in developing the IEE through discussions on-site and public consultation. Their views were incorporated into the IEE, and the design of the project. The IEE will be made available at public locations in the town such as Municipal office building, district administration office, and site office of ASU. It will be disclosed to a wider audience via the ADB and ASDM websites.

vicinity of ASU site, there are no environmentally and/or ecologically protected areas (national parks, wild-life or bird sanctuaries, tiger reserves, bio-spheres, forests, etc.), wetlands, mangroves, or estuaries in or near the sub-project location. There are no archeologically protected monuments, structures or heritage sites within 300 m distance of ASU plot boundary. The ASU site is a plain terrain.

7. Since the boundary wall construction along the external limits of ASU delineated site (total length of about 3 km) will involve minor civil works, there will not be any significant adverse environmental impacts. The minor impacts will be limited during construction period only. There will be no environmental impacts in the operation phase. These routine and localized effects associated with construction can be mitigated easily by following the measures laid down in the **Environment Management Plan (EMP)** included in the IEE report. The EMP will be included in civil work bidding and contract documents. **The IEE confirms that boundary wall construction, for ASU site, as environment category “B”.** No further special study or detailed environmental impact assessment (EIA) needs to be undertaken to comply with ADB SPS, 2009 or Government of India EIA Notification, 2006.

8. A ‘with’ and ‘without’ subproject scenario has been considered to justify the subproject. Location and design of the boundary wall was also considered for its likely impacts on environment.

9. PMU at ASDM will be responsible for overall planning and implementation of the civil works. To assist PMU in implementation, project management consultants (PMC) will be appointed. PMU and PMC will ensure that the EMP is followed during construction phase. The PMU and PMC firm will have experienced environment and social safeguards specialists. The EMP implementation will be monitored by the environment safeguard specialists of PMU and PMC.

10. The project will have a grievance redress mechanism (GRM) to address grievances of aggrieved party or persons. The GRM will be transparent, easily accessible and time bound for the resolution of grievances. The details of GRM have been provided in IEE report.

I. INTRODUCTION

A. Background

1. **Location.** The proposed location of ASU is near Mangaldoi in Darang district of Assam. The latitude and longitude of the ASU site are given below:

Sl. No.	Name of Facility	Latitude	Longitude
1	Assam Skill University	26°25'21.36"N	92° 0'53.93"E

2. The nearest rail head to Mangaldoi is Tangla at about 35 km and Rangia Junction 48 km away from the ASU site. The project site is well connected to important destinations such as Guwahati, New Jalpaiguri, Rangia and Nalbari. The distances of important destinations are given below:

Sl. No.	Name of Facility	Altitude (m)	District	Distance from ASU site
1.	ASU	51.24	Darrang	Guwahati Airport : 70 Km Guwahati City : 72 Km Tezpur : 107 Km Nalbari : 68 Km IIT Guwahati : 52 Km Udalguri : 43 Km Alipurduar : 303 Km Cooch Behar : 323 Km Darrang : 5 Km Barpeta : 123 Km Morigaon : 141 Km

3. The proposed Skill University site is a vacant land in the ownership of Assam Skill Development Mission (ASDM), Government of Assam. The Darrang district geographically lies between the latitude 20° 9' N to 26.96° North and longitude 91° 45' E to 92° 22' East.

4. **Present Status of ASU Site:** The ASU site is a plain terrain. The site ownership is with Assam Skill University. There are no permanent or temporary structures on the site. There are also no trees at site. The photographs of the ASU site are shown below.





View of Site Showing Plain Terrain



Another view of site showing Plain Terrain



View of Site showing no Presence of Trees or Shrubs

B. Compliance with India's Environmental Regulatory Framework

5. India's environmental rules and regulations, as relevant for the construction of boundary wall of ASU, are shown in **Table 1**. The Environmental Impact Assessment (EIA) Notification, 2006 issued by the Ministry of Environment, Forests and Climate Change (MOEFCC, GOI) specifies the requirements for mandatory environmental clearances. All projects and activities are broadly categorized into two categories—category 'A' and category 'B', based on the spatial extent of potential impacts on the environment, human health, and natural and man-made resources². However, MOEFCC's Notification- S.O. 3252,

² All projects or activities included as Category 'A' in the Schedule, including expansion and modernization of existing projects or activities and change in product mix, will require prior environmental clearance from the Central Government in the Ministry of Environment, Forests and Climate Change (MoEFCC) on the recommendations of an Expert Appraisal Committee (EAC) to be constituted by the Central Government for the purposes of this notification; All projects or activities included as Category 'B' in the Schedule, including expansion and modernization of existing projects or activities as specified in sub paragraph (ii) of paragraph 2, or change in product mix as specified in sub paragraph (iii) of paragraph 2, but excluding those which fulfill the General Conditions stipulated in the Schedule, will require prior environmental clearance from the State/Union territory Environment Impact Assessment Authority (SEIAA). The SEIAA shall base its decision on the recommendations of a State or Union territory level Expert Appraisal Committee (SEAC) as to be constituted for in this notification. In addition, General Condition (GC) of the notification specifies that any project or activity

dated 22/12/2014 exempts all educational and training institutes from obtaining prior environmental clearance. Since all the ASU components to be constructed including the boundary wall construction will not require any prior environmental clearances according to the environmental rules and regulations of India. Further, as shown in **Table 1**, most other rules pertaining to India's regulatory framework such as Ancient Monuments and Archaeological Sites and Remains Act, 1958; the Wildlife (Conservation) Act, 1972, amended in 2003 and 2006; and the Forest (Conservation) Act, 1980, will also not apply to Boundary Wall construction of ASU. Permission will be required from the State Pollution Control Board, GoA for the construction phase of the sub-project.

Table-1: Environmental Regulatory Compliance

Sub-Project	Applicability of Acts/Guidelines	Compliance Criteria
Construction of Boundary wall of ASU	The EIA notification, 2006 (and its subsequent amendments till date) provides for categorization of projects into category 'A' and 'B', based on extent of impacts.	The sub-project is not covered in the ambit of the EIA notification (amended till date), either as a Category 'A' or Category 'B' project. As per the MOEFCC Notification S.O. 3252 dated 22/12/2014, educational and training institutions are exempted from prior environmental clearance (Annexure-1). As a result, the categorization, and the subsequent environmental assessment and clearance requirements, either from the state or the GOI, are not triggered. Not Applicable
	The Ancient Monuments and Archaeological Sites and Remains Act, 1958, and the rules, 1959 provide guidance for carrying out activities including conservation, construction and reuse in and around the protected monuments.	The ASU site is not close to any monument which is protected by the Archaeological Survey of India (ASI). Hence, no clearance is needed from ASI. Not Applicable
	Water (Prevention and control of pollution) Act, 1974 and Air (prevention and control of pollution) Act, 1981	Consent for Establishment (CFE) and Consent for Operation (CFO) from the State Pollution Control Board will be required during construction for installation of diesel generator set, hot mix plant, and concrete batching plant. The CFE will also be required for Assam Skill University project. For the operation phase, no CFO will be required for the boundary wall, but for ASU project, CFO will be required for Sewage Treatment Plant, and backup power Generator. Applicable
	The Wildlife Conservation Act, 1972, amended in 2003 and 2006, provides for protection and management of Protected Areas.	No wildlife protected areas within 15 km aerial distance from the ASU site. Not Applicable

specified in Category 'B' will be treated as Category A, if located in whole or in part within 5 km from the boundary of: (i) Protected Areas notified under the Wild Life(Protection) Act, 1972, (ii) Critically Polluted areas as notified by the Central Pollution Control Board from time to time, (iii) Notified Eco-sensitive areas, (iv) inter-State boundaries and international boundaries.

Sub-Project	Applicability Acts/Guidelines	of	Compliance Criteria
	Forest (Conservation) Act, 1980	Act,	<p>This act provides guidelines for conservation of forests and diversion of forest land for non-forest use. It describes the penalties for contravention of the provisions of the Act. If forest land has to be acquired for the project, clearance is required from the Forest Department. No forest land is required to be used for the ASU. Hence, this is not applicable.</p> <p>Not Applicable</p>

C. Asian Development Bank’s Environmental Safeguard Policy Principles

6. Since the proposed project is being funded by the ADB, it has to comply with ADB’s SPS, 2009, in addition to the India’s environmental laws and regulations applicable at the national, state and local levels. The environmental safeguard policy principles embodied in SPS, 2009 aim to avoid adverse impacts on the environment and on affected people or communities; minimize, mitigate and/or compensate for adverse project impacts, if unavoidable; help borrowers to strengthen their safeguard systems and to develop their capacity in managing the environmental and social risks. The SPS, 2009 categorizes all projects into 3 environmental categories (A, B or C) based on their potential impacts³. Similarly, ADB’s rapid environmental assessment (REA) checklist was used to assess the potential impact of the proposed ASU Boundary wall (**Annexure-2**). As explained in Annexure-1, ASU boundary wall construction has been categorized as 'B'. Accordingly, this IEE has been prepared to address the potential impacts in line with the requirements for category B projects. The IEE was based mainly on baseline data generation on environmental parameters and secondary sources of information and field reconnaissance surveys. Stakeholder consultations at ASU site are an integral part of the IEE. An EMP outlining the specific environmental measures to be adhered to during implementation of the sub-projects is included in the IEE.

D. Review and Approval Procedure

7. For Category 'B' projects, the draft initial environmental examination Report is reviewed by the relevant ADB departments and the EA. Additional comments are incorporated into the final documents as relevant. These are reviewed by the EA and ADB safeguards team. The EA then officially submits the IEE report to ADB for review and clearance. The final IEE report will be disclosed in ADB’s website in accordance with ADB’s Access to Information Policy. The EA will also disclose the IEE report to the stakeholders in a form and language understandable to the communities through information booklets, pamphlets, etc.

³ As per SPS 2009, projects are assigned to one of the following four categories: (i) **Category A**. A proposed project is classified as category A if it is likely to have significant adverse environmental impacts that are irreversible, diverse, or unprecedented. These impacts may affect an area larger than the sites or facilities subject to physical works. An environmental impact assessment is required. (ii) **Category B**. A proposed project is classified as category B if its potential adverse environmental impacts are less adverse than those of category A projects. These impacts are site-specific, few if any of them are irreversible, and in most cases mitigation measures can be designed more readily than for category B Project. An initial environmental examination is required. (iii) **Category C**. A proposed project is classified as category C if it is likely to have minimal or no adverse environmental impacts. No environmental assessment is required although environmental implications need to be reviewed (iv) **Category FI**. A proposed project is classified as category FI if it involves investment of ADB funds to or through a financial intermediary (FI) (paras. 65-67).

E. Report Structure

8. This report contains eight sections including this introductory section: (i) Introduction; (ii) description of sub-project components; (iii) description of the existing environment around the sub-projects; (iv) environmental impacts and mitigation measures; (v) EMP; (vi) public consultation and information disclosure; (vii) findings and recommendations; and (viii) conclusions.

II. DESCRIPTION OF THE PROJECT COMPONENTS

A. Components of the ASU Project

9. The location of the ASU site, where boundary wall construction is planned, has been shown in **Figures 1 and 2**. **Table -2** summarizes the need for the boundary wall and brief description of its components.

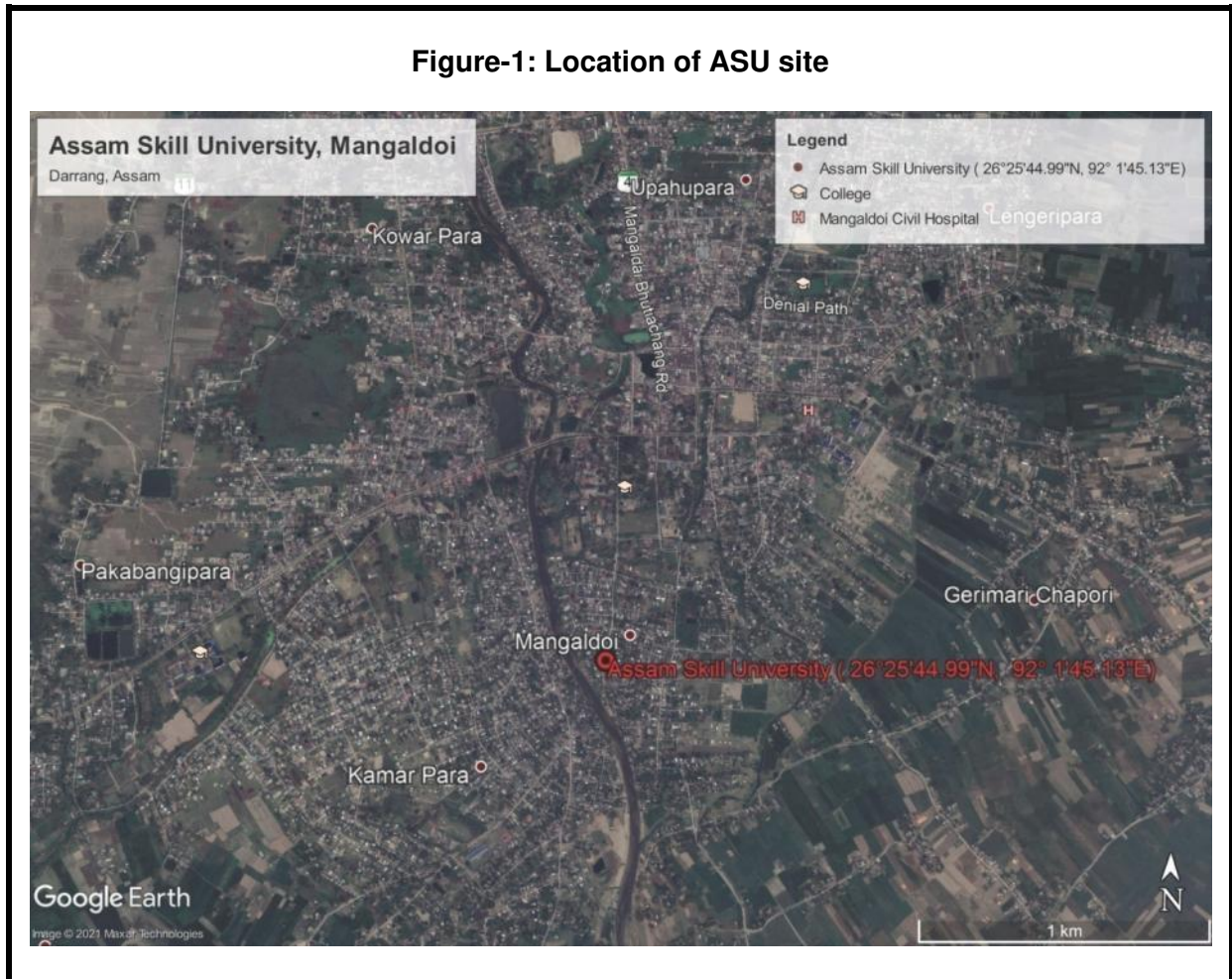

Figure-2: Location of ASU Site

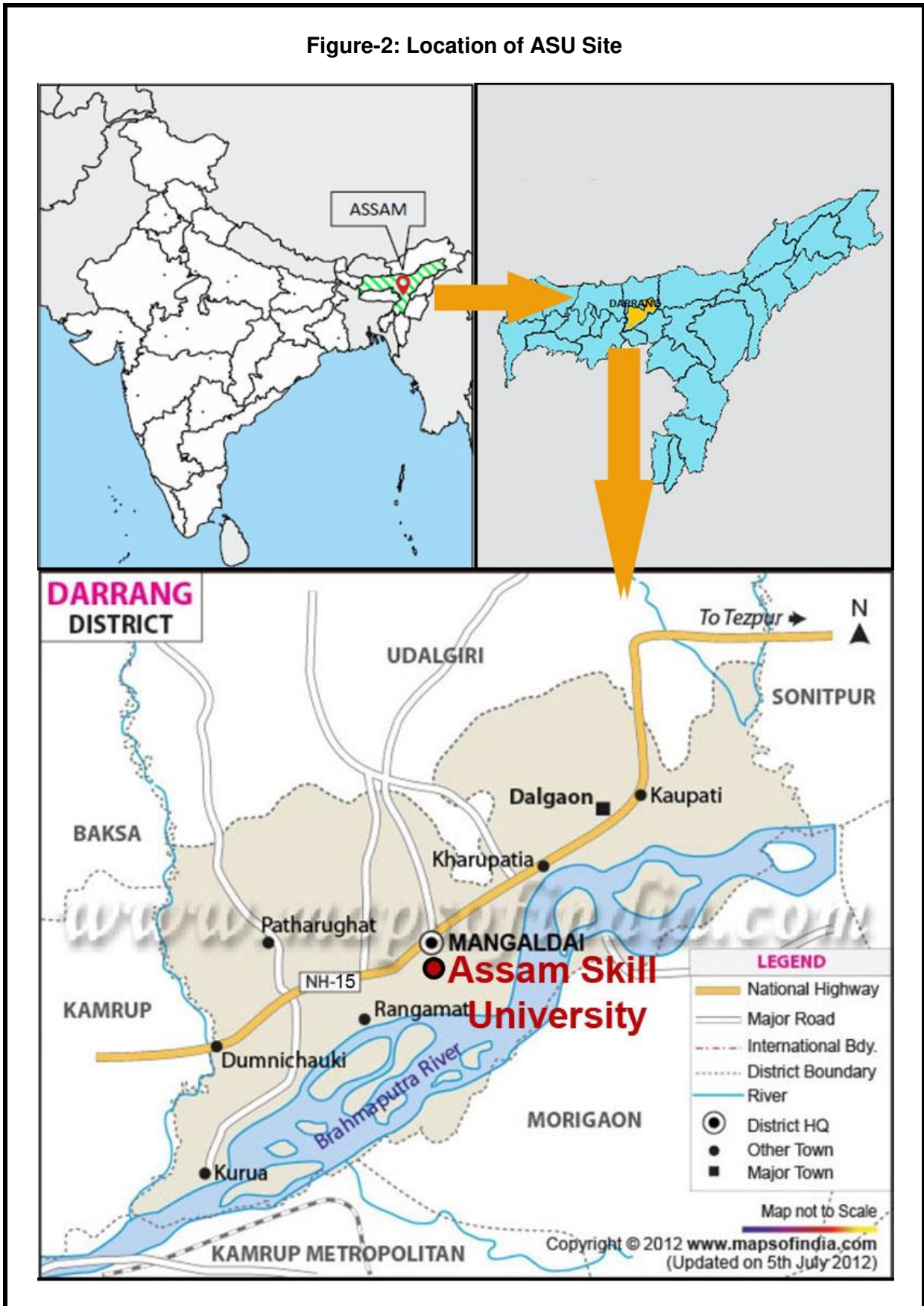
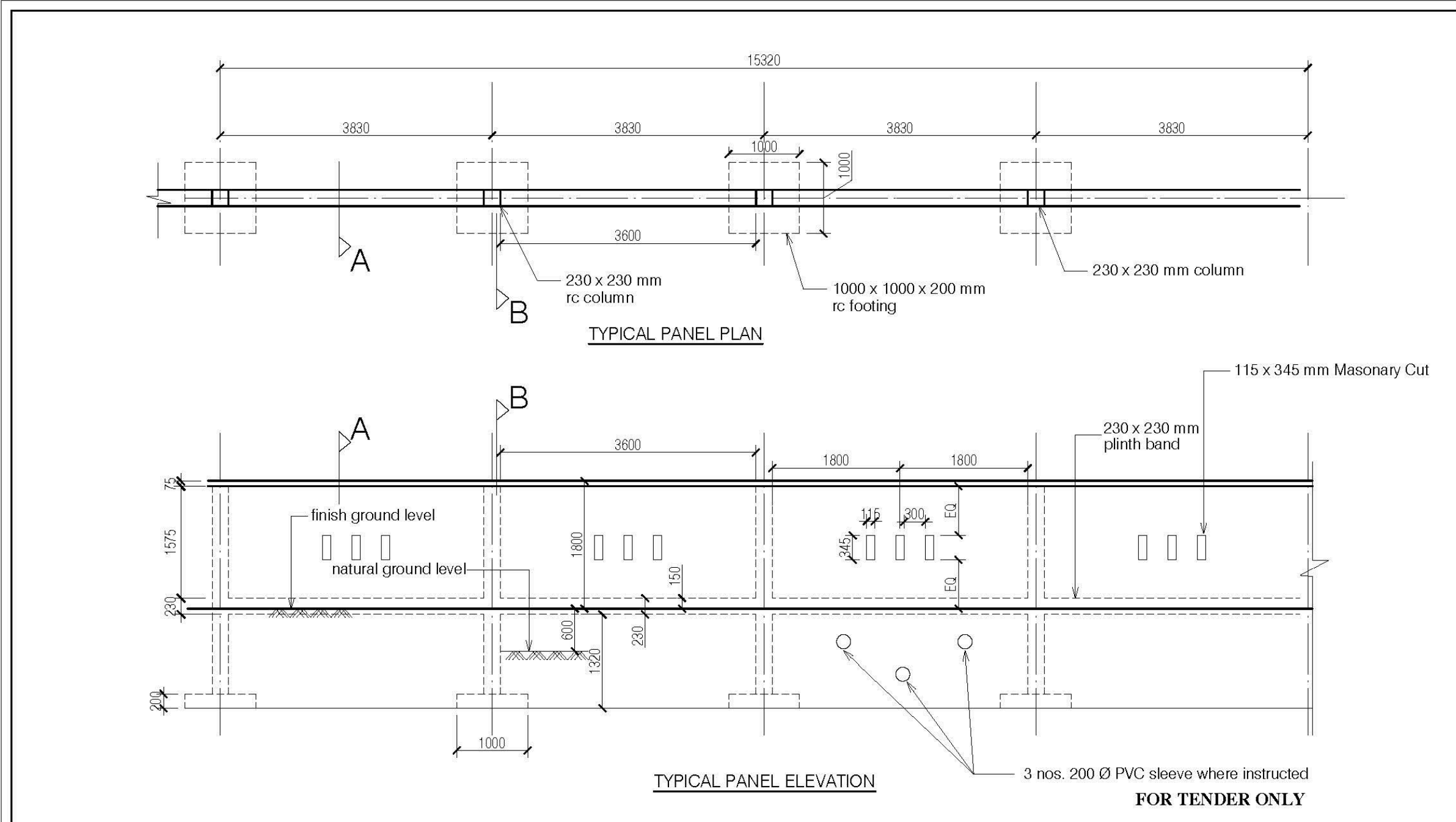

Table-2: Description of the ASU Boundary Wall Components

Description	Need of the Sub-project	Proposed Components
Construction of Boundary Wall for ASU site	<ul style="list-style-type: none"> • The ASU will offer industry-aligned and flexible skills education and training programs. This will contribute to overall economic growth of the northeastern states. • The ASU component pertaining to boundary wall construction is being taken up to secure open land allotted by the Government of Assam. 	<p>The main ASU boundary wall components include:</p> <ol style="list-style-type: none"> i. In the front portion of site, there will be chain link fencing and construction of temporary gate (Length about 300m). ii. On the other sides, there will be boundary wall with brick work having cement plaster and water proof cement paint (Length about 3.0 km). The height of boundary wall be 1.8 m from the finish ground level. iii. There will be no other construction on plot as part of this contract.

10. The plan and elevations of boundary wall have been shown below in **Figure-3**.

Figure-3: Plan and Elevations of Boundary Wall



PROJECT :		ASSAM SKILLS UNIVERSITY	
SHEET TITLE		Date 20-01-2021	
BOUNDARY WALL (PLAN & ELEVATION)		Scale 1:125	
ARCHITECTS		DRG. No.	
		01	

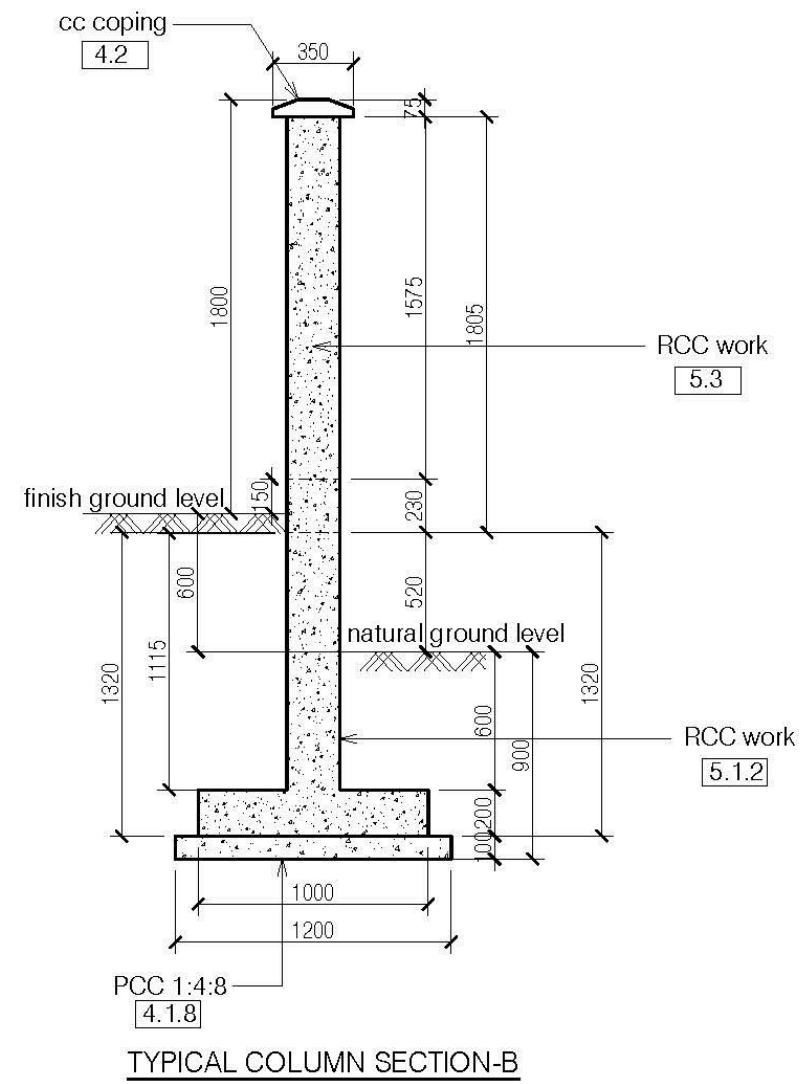
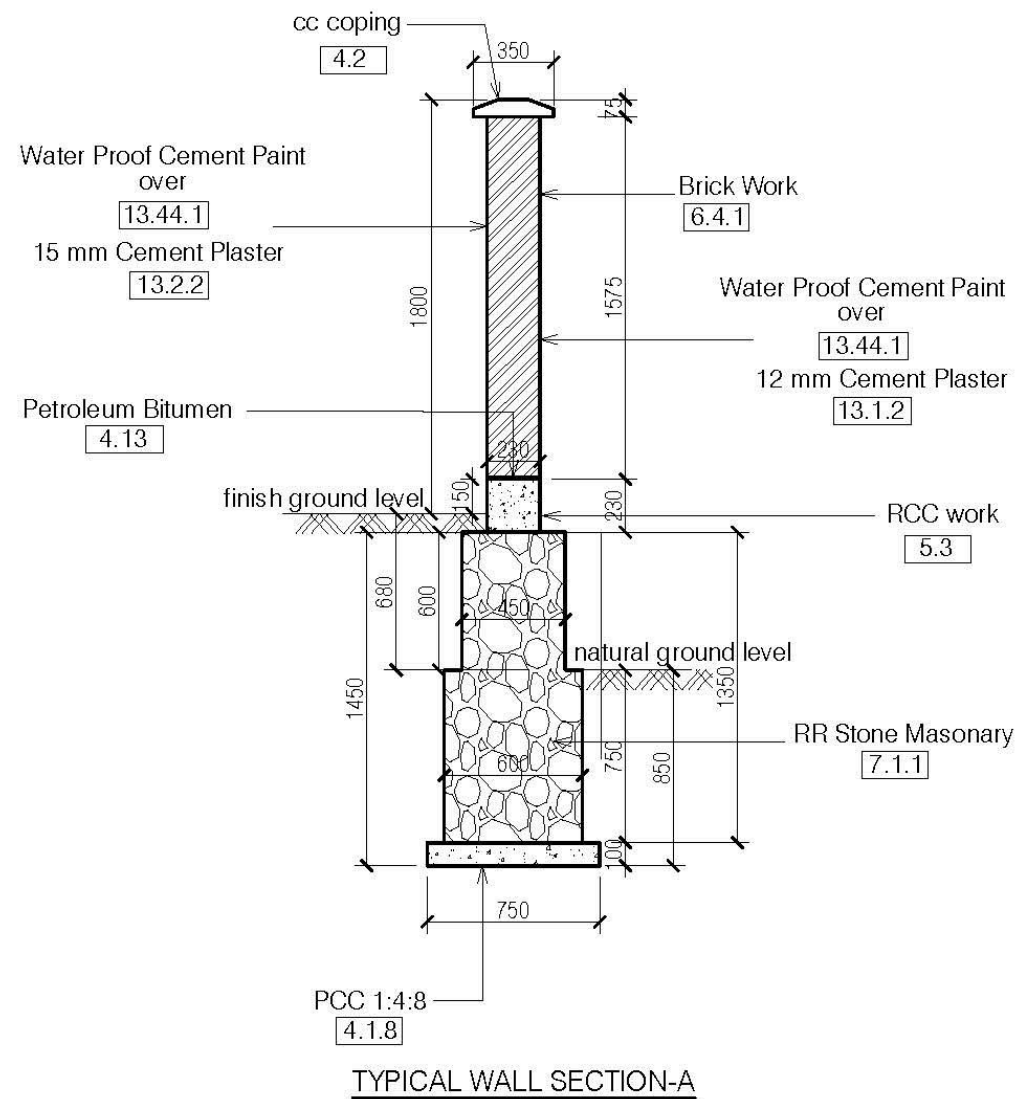

FOR TENDER ONLY

CODE	
2.8.1	Excavation for Foundations
2.25	Filling Earth
4.3	Centering and Shuttering
5.22	Steel reinforcement for R.C.C. work

PROJECT :		ASSAM SKILLS UNIVERSITY	
SHEET TITLE		Date 20-01-2021	
BOUNDARY WALL (SECTIONS)		Scale 1:125	
ARCHITECTS		DRG. No.	
		02	

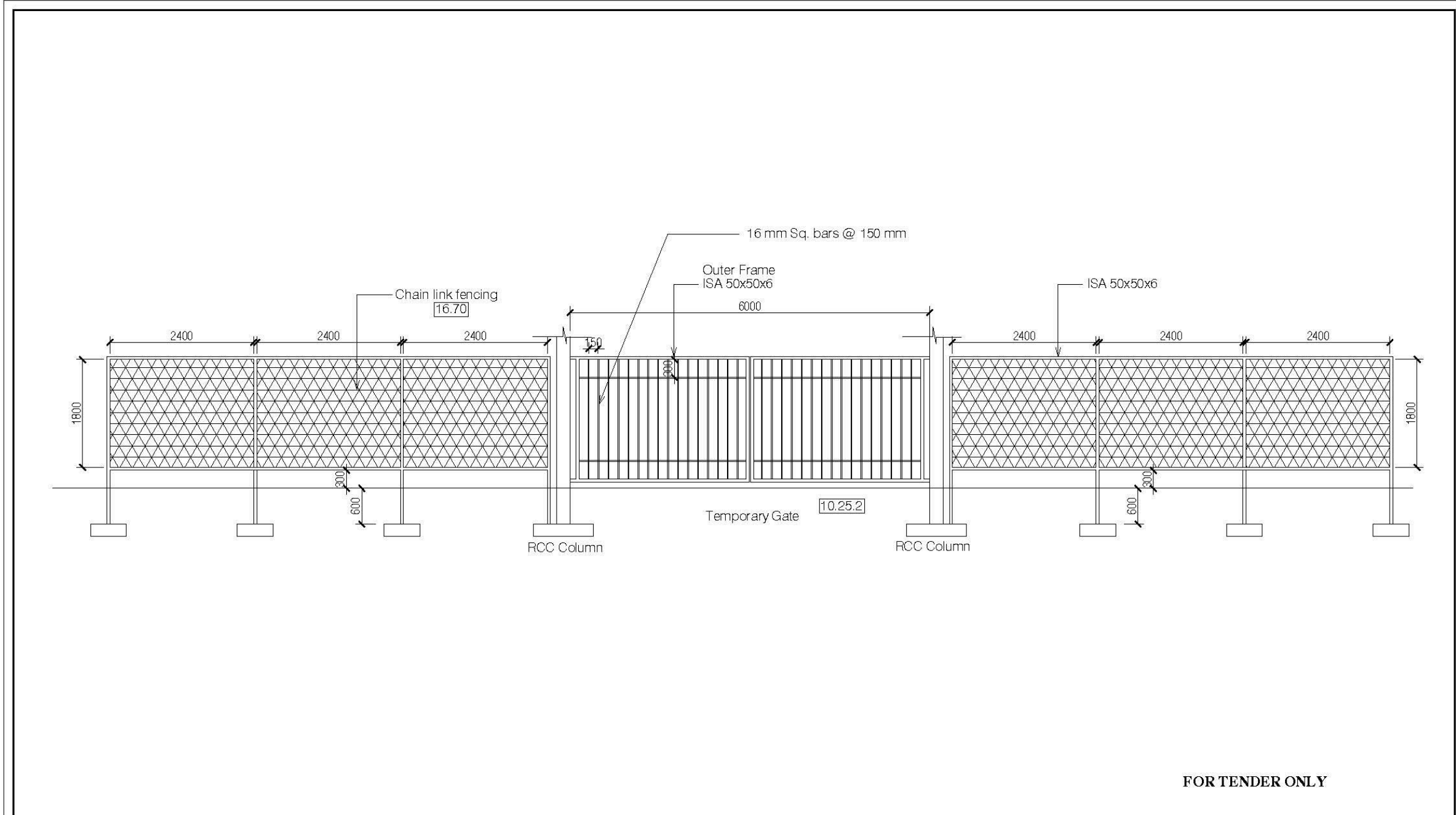

FOR TENDER ONLY

CODE	
2.8.1	Excavation for Foundations
2.25	Filling Earth
4.3	Centering and Shuttering
5.22	Steel reinforcement for R.C.C. work

PROJECT :		ASSAM SKILLS UNIVERSITY	
SHEET TITLE		Date 20-01-2021	
CHAIN LINK FENCING ELEVATION		Scale 1:125	
ARCHITECTS		DRG. No.	03

B. Executing and Implementing Agencies

11. The Skill, Employment and Entrepreneurship Department (SEED) of GoA is the EA. The Assam Skill Development Mission (ASDM) is the IA. The ASDM has established a project management unit (PMU) for the overall project implementation. For the civil works components, the ASDM will be supported by the PMC team. The PMC team will be a multi-disciplinary team including environmental specialist having thorough knowledge of environmental rules and regulations of the State and Gol and other environmental management aspects. The ASDM will be responsible for overall planning and implementation of the civil works. ASDM will ensure that the ASU and all activities financed under the ADB comply with environmental rules and regulations of Gol and GoA and ADB SPS 2009.

C. Implementation Schedule

12. The implementation period for the proposed boundary wall of is6months. The preliminary drawings for boundary wall have been prepared for approval and these are in the process of approval. The bidding process for the ASU boundary wall will start by February 2021. The ASU boundary wall contract will be awarded for construction by the end of April/May 2021. The contractor is expected to be mobilized on site by May 2021, but on account of intense monsoon in Assam, construction works of ASU will begin in October after the monsoon season is over and the works will be completed by March 2022.

III. DESCRIPTION OF THE EXISTING ENVIRONMENT FOR ASU SITE

13. This section presents a brief description of the existing environment around the ASU site, including its physical resources, ecological resources, socio-economic development and social and cultural resources. Broad aspects on various environmental parameters such as geography, climate and meteorology, physiographic, geology, seismology, ecology, socio-cultural and economic development parameters that are likely to be affected by the proposed boundary wall are presented. Secondary information was collected from relevant government agencies like the Forest Department, State Environment Department and State Pollution Control Board, and Meteorological Department.

A. Environmental Profile

Air and Noise Quality

14. No air pollution sources have been seen in the surroundings of project site as site is in open area near Mangaldoi town. There is no baseline ambient air quality available for Mangaldoi town and ASU site. Baseline ambient air quality monitoring will be carried out by the contractor in pre-construction phase immediately after mobilization.

15. Noise levels data is not available for the ASU site as the site is quite remote. In order to have site specific ambient air quality monitoring and noise levels data, monitoring will be conducted by the contractor prior to start of construction works with the aim of establishing baseline conditions.

16. **Climate.** Three seasons are witnessed in Mangaldoi. From February to May weather is dry. In the month of March north-east winds carry sand and dust. In April and May local rains along with thunderstorms are a common feature. The maximum and minimum temperature varies from 12^o to 31^o C during this period. From June to October, there is prevalence of south-west monsoon with heavy rainfall. Temperature varies from 22 to 32^oC in this season. Average annual rainfall is 1637.3 mm in the region with about 87 rainy days. About 90 % of rain occurs between April and September and July and August being the rainiest months.

17. **Temperature.** The temperature exhibits seasonal variation with minimum during the winter and higher during the summer. June, July and August are the hottest months while January and December are the cold months. The maximum temperature rises to about 32^oC (89 ^oF) in August and the minimum temperature falls to about 11^oC (52 ^oF) in winter months. The **Figure-4** below shows month wise Temperature data at Mangaldoi.

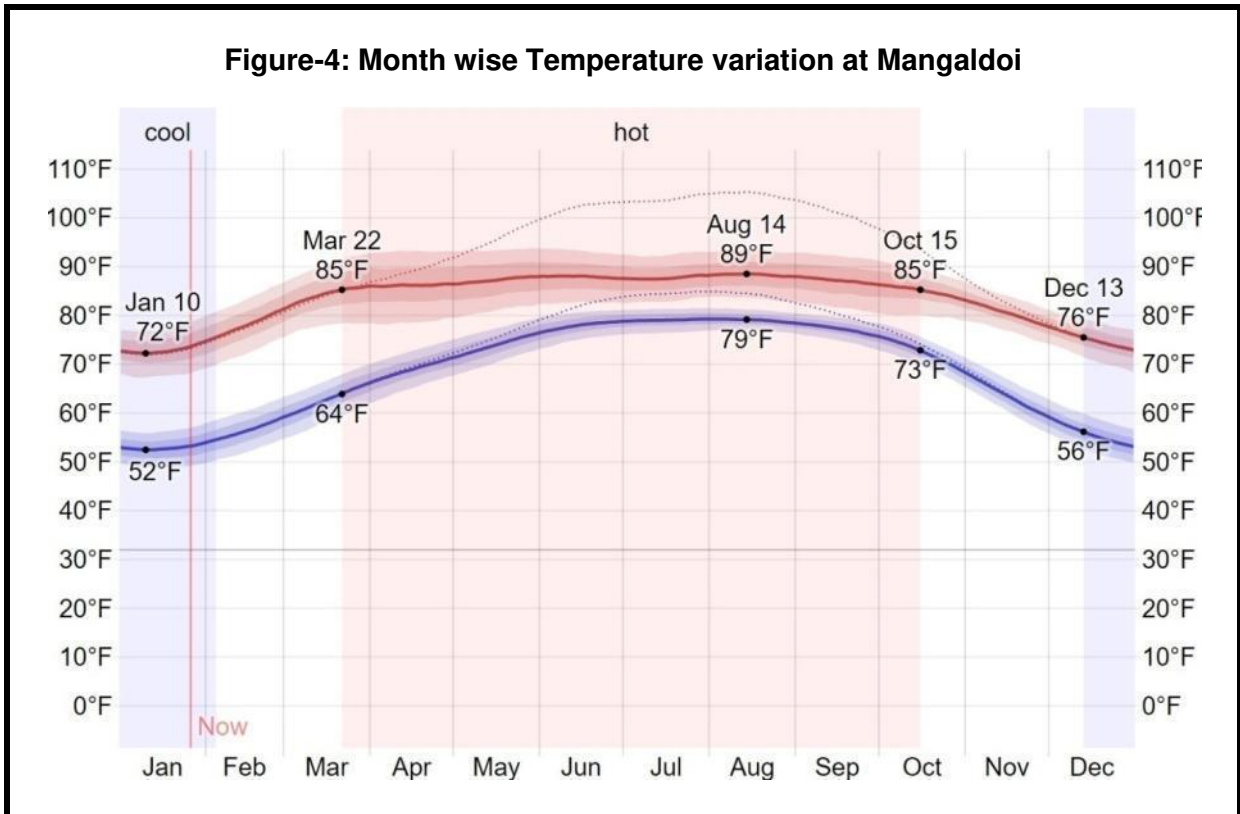

Source: <https://weatherspark.com/y/112086/Average-Weather-in-Mangaldai-India-Year-Round>

18. **Rainfall.** The sub-project area experiences maximum rainfall during Monsoon season from June to October while as least Rainfall is received in November and December. Average annual rainfall at Mangaldoi is around 1600 mm. The month wise rainfall for Mangaldoi has been shown in **Figure-5**.

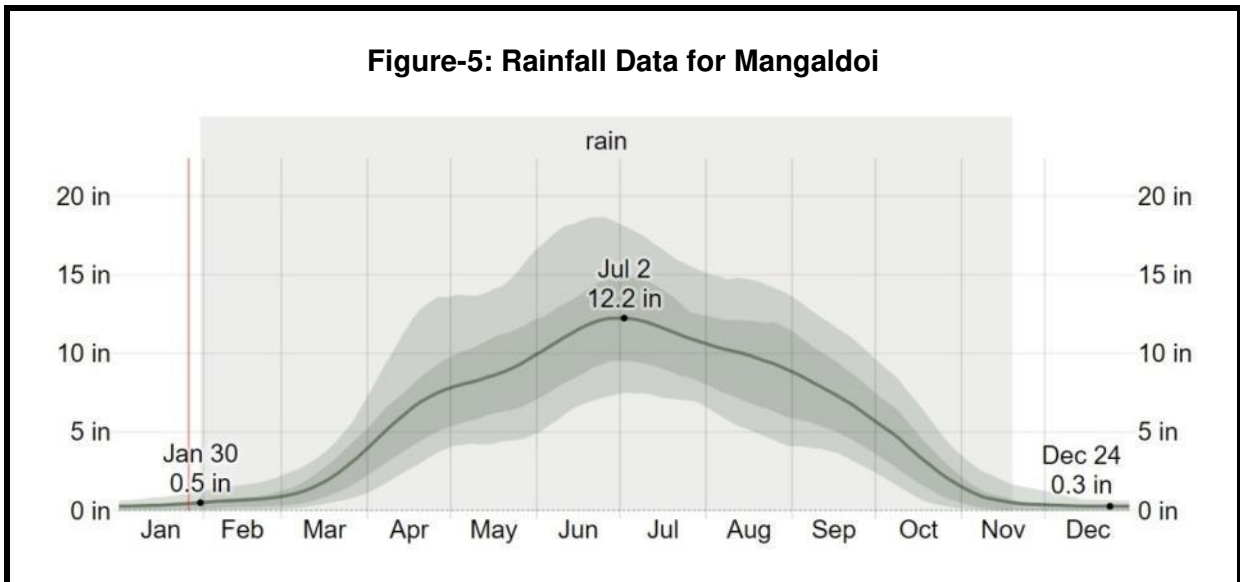

Source: <https://weatherspark.com/y/112086/Average-Weather-in-Mangaldai-India-Year-Round>

19. **Humidity.** Based on climatological data of the Mangaldoi, it is found that relative humidity increases rapidly with the onset of monsoon and reaches maximum (around 96%) during August, when peak monsoon period sets in. Relative humidity is the minimum during the summer months (from April to June) with February being the driest month (around 6%). Skies are heavily clouded during the monsoon months.

20. **Wind Speed and Directions.** Generally, light to moderate winds prevail throughout the year. Average wind speed from February to June is 8.50 kmph. The wind speed is about 7.10 kmph from July to January. Peak wind speed in March month is about 9.5 kmph.

Topography and Soils

21. The topography of project site is plain. The average elevation of the site is 51.24 m above mean sea level. Physiographically the entire Darrang district is an alluvial plain with flat topography and there is a very gentle slope towards Brahmaputra River, which makes the southern boundary of the district. The district has soil cover of younger alluvium and older alluvium which have undergone diversified pedagogical changes. The soils are characterized by medium to high organic carbon, low to medium phosphate and potash contents. The alluvial soils are light yellow to light grey in color of recent age. At the project site soils are light grey in color. The texture of the soil ranges from sandy loam to silty loam in nature. At the site texture of soils is silty loam. The soil is suitable for cultivation of rice crop. In order to characterize the baseline soil quality data was collected from secondary published sources for project region. It has been given in **Table-3**:

Table-3: Soil Quality Data for Sub-Project Region

Sl. No.	Parameter	Unit	Value
1	Color	-	Brownish
2	pH	-	6.2
3	Conductivity	Micro mhos/cm	593
4	Bulk Density	gm/cm ³	1.14
5	Porosity	%	42.60
6	Water Holding Capacity	%	33.80
7	Texture	-	Sandy –Loam
8	Sand	%	22
9	Silt	%	17
10	Clay	%	29
11	Gravel	%	32
12	Organic Matter	%	1.9
13	Calcium as Ca	%	0.43
14	Magnesium as Mg	%	0.20
15	Sodium	%	0.66
16	Potassium	%	0.15
17	Sulphur	%	0.08
18	Nitrogen	%	0.21
19	Phosphorus	%	0.16
20	CEC	Meq/100 gm	27.9
21	Copper	mg/kg	2.3
22	Chromium	mg/kg	ND
23	Zinc	mg/kg	4.4
24	Lead	mg/kg	0.50

Source: Environmental Impact Assessment Report for Installation of 2 Mounded Bullets at Guwahati Refinery, Year 2017

Surface water and Ground water

22. The ASU site is located in Brahmaputra river catchment (at a distance of about 5 km in monsoon season). There is no major surface water source close to the site. The groundwater quality data for Mangaldoi is not available. In order to establish baseline, environmental monitoring will be taken up for ground and surface water quality.

23. Based on 2012 data of Central Ground Water Board (CGWB), the depth of water level during pre-monsoon months, in Darrang district ranged from 2.0 to 4 m below ground level (bgl) and 1 to 2 m in post monsoon months. The stage of ground water development in Darrang district is only 31 % and district does not fall in critical category for ground water development. The hydrogeology map of Darrang district has been shown in **Figure-6**.

24. Since Brahmaputra is the only river of significance in the project region so water quality data of this river was obtained from past EIA study. This river in future may be source of drinking water supply in Darrang town. The aerial distance of this river from site is about 5 km in monsoon season. This data has been given below in **Table-4**. It is clear from this table that heavy metals like copper, lead, mercury, cadmium and chromium were below their respective detection limits in the river water. Brahmaputra River generally conforms to Class-C & D of the CPCB, which means the water is suitable for outdoor bathing and as drinking water source after conventional treatment and disinfection.

Table-4: Brahmaputra River Water quality in Sub-Project Region

Sl. No.	Parameter	Unit	Value	Permissible Limit as per Drinking Water Standards
1	pH	-	7.4	6.5 to 8.5
2	Conductivity	Micromhos/cm	288	-
3	Dissolved Oxygen	mg/l	6.7	-
4	BOD (3 Days 27°C)	mg/l	3	10
5	Total Coliforms	MPN/100 ml	640	Nil
6	Total Dissolved Solids	mg/l	168	2000
7	Oil and Grease	mg/l	1.4	-
8	Cyanide as (CN)	mg/l	<0.005	-
9	Phenol	mg/l	<0.001	-
10	Total Hardness (as CaCO ₃)	mg/l	99	600
11	Chloride (as Cl)	mg/l	25	1000
12	Sulphate (as SO ₄)	mg/l	3	400
13	Nitrate (as NO ₃)	mg/l	1.6	100
14	Fluoride (as F)	mg/l	0.2	1.5
15	Calcium (as Ca)	mg/l	28	200
16	Magnesium (as Mg)	mg/l	7	30
17	Copper (as Cu)	mg/l	<0.05	-
18	Iron (as Fe)	mg/l	0.40	1.0
19	Manganese (as Mn)	mg/l	<0.05	-
20	Zinc	mg/l	0.06	-
21	Boron (as B)	mg/l	<0.02	-
22	Arsenic (as As)	mg/l	<0.002	-
23	Mercury (as Hg)	mg/l	<0.001	-
24	Lead (as Pb)	mg/l	<0.05	-

Assam Skill University Project
Initial Environmental Examination for Boundary Wall Construction

Sl. No.	Parameter	Unit	Value	Permissible Limit as per Drinking Water Standards
25	Cadmium (as Cd)	mg/l	<0.01	
26	Alkalinity (as CaCO ₃)	mg/l	128	
27	Hexavalent Chromium as Cr+6	mg/l	<0.05	

Source: Environmental Impact Assessment Report for Installation of 2 Mounded Bullets at Guwahati Refinery, Year 2017

Figure-6: Hydrogeology Map for Darrang District

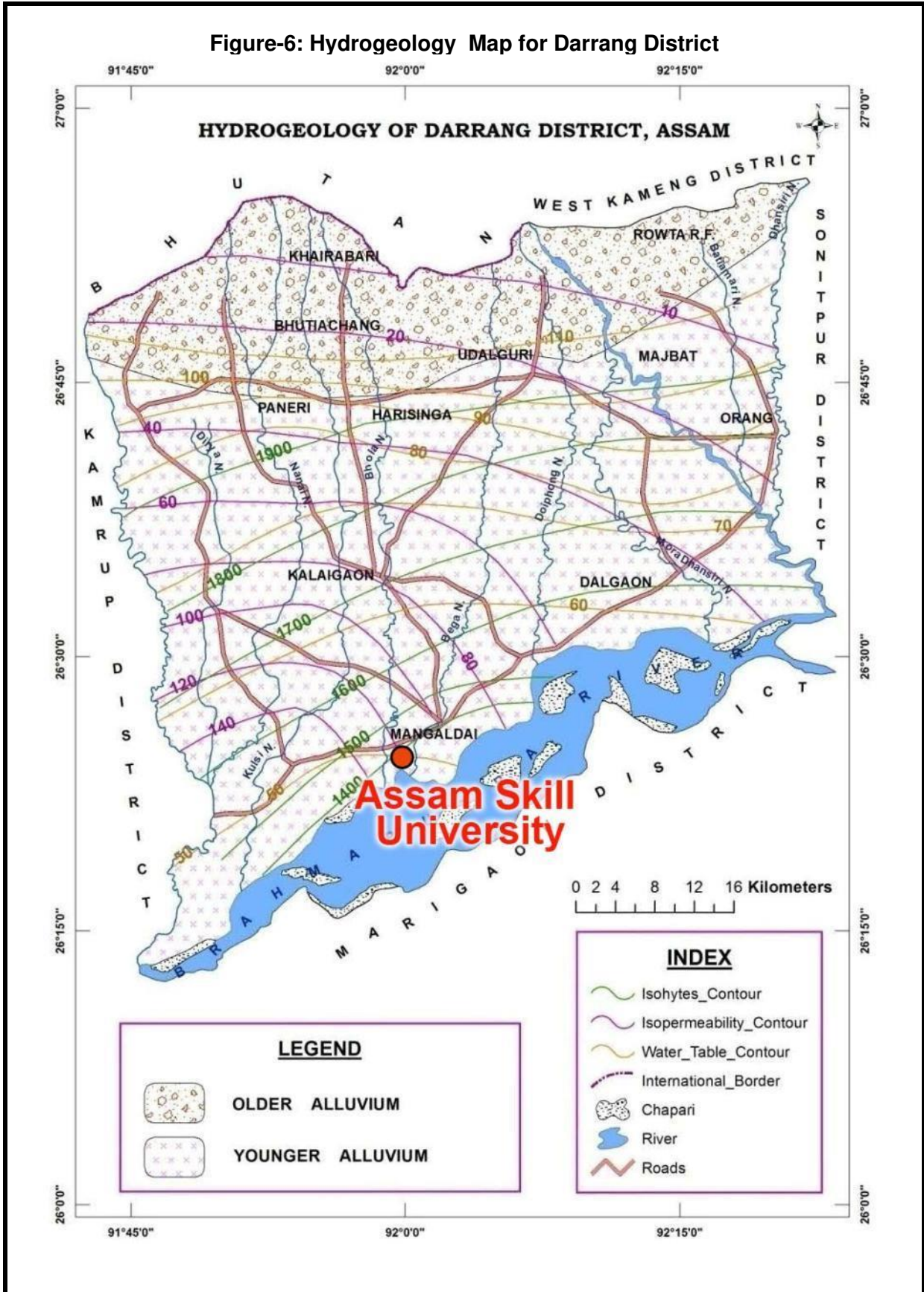

Source: Ground Water Information Booklet Darrang District, Assam -Central Ground Water Board (Year-2013)

Geology and Seismology

25. Geologically the project region (Darrang district) is occupied by Quaternary sediments of older and younger alluvium, where, the northern foothill part is covered mostly by old alluvium consisting of clay, sand, gravel, pebble and boulder, on the other hand, the southern new alluvium contains clay, silt and fine sand in maximum proportions. With favorable physiographical, geological, lithological and climatic factors, the project area happens to be an area of large reserve of under-ground water in regionally extensive aquifers up to a depth ranging from 50 to 300 m.

26. India's seismic code divides the country into five seismic zones (I to V). The sub-project stretch comes under seismic zone V as defined by Urban Earthquake Vulnerability Project (UEVP) and the Atlas prepared by the Building Materials Promotion and Technology Council (BMTPC), Government of India and UNDP [IS 1893 (Part I : 2002)]. All structures have been designed considering seismic zone V. It may be mentioned that intensity of earthquake increases from Zone I to V. The Zone V mainly covers entire northeastern India, parts of Himachal Pradesh, Uttaranchal, Rann of Kutch in Gujarat, parts of North Bihar and Andaman & Nicobar Islands. Zones I, II and III mainly cover Central and Southern parts of Indian peninsula. As mentioned above Zone 5 covers the areas with the highest risk of suffering earthquakes so IS code assigns a zone factor of 0.36 for Zone 5. Structural designers use this factor for earthquake resistant design of structures in Zone 5.

Drainage

27. The ASU site drained by Brahmaputra River (at distance of about 5 km in monsoon months) and its tributaries. No flooding issues have been reported at the site. All the structures of ASU will be 2 feet above High Flood Level (HFL). The site is not in the river land.

B. Ecological Resources

(i) Forests

28. Various types of forests in Assam currently cover an area of nearly 28326.51km², which is about 36.11% of the total land area of the state. The variation in the landscape has created great diversity of flora and fauna. In terms of forest canopy density classes, the State has 2794.86 sq km under Very Dense Forest (VDF), 10278.91 sq km under Moderately Dense Forest (MDF) and 15252.74 sq km under Open Forest (OF). Darrang district has about 5.64 % forest of total geographic area of the district. The most portions of these forest areas are managed by the Forest Department. The forest areas under very dense, moderately dense and open category are presented below in **Table-5 for Darrang** district.

Table-5: Different Categories of Forests Darrang District

District	Very Dense Forest Area (km ²)	Moderately Dense Forest Area (km ²)	Open Forest Area (km ²)
Darrang	0	13.89	75.54
<i>Source : State Forest Department (Forest Survey of India Report -Year 2019)</i>			

29. Five major groups of forests in Assam have been identified. These are (1) Tropical Wet Evergreen Forest, (2) Tropical Semi-evergreen Forest, (3) Tropical Moist Deciduous Forest, (4) Littoral and Swamp Forest and (5) Tropical Dry Deciduous Forest.

30. The ASU site does not fall within any reserved, protected, or revenue forest areas. The forest area in Darrang district is low because it is an agriculture prone area and in flood plains of Brahmaputra.

(ii) Flora and Fauna around ASU Site

31. The ASU site is at the outer skirts of Mangaldoi town. There are no protected areas within 15 km radius. Around the ASU site, one only finds domesticated fauna. At present there are no trees at site. There is presence of shrubs. The common trees in the surroundings of ASU site are given in **Table-6** below:

Table-6: Common Tree Species around ASU Site

Sl. No.	Scientific Name	Common Name
1.	<i>Aegle marmelos</i>	Bel
2.	<i>Alangiumchinense</i>	Kodalkonia
3.	<i>Albizia lucida</i>	Hoj
4.	<i>Albiziaodoratissima</i>	Chamkorai Heharu
5.	<i>Acrocarpusfraxinifolius</i>	Mandhani
6.	<i>Acrocarpusintegrifolia</i>	Borpat
7.	<i>Acrocarpusprocera</i>	Korai
8.	<i>Anona squamosa</i>	Custard apple
9.	<i>Azadirachtaindica</i>	Neem
10.	<i>Bauhinia purpurea</i>	Kanchan
11.	<i>Brideliaretusa</i>	Kohir
12.	<i>Bauhinia malabarica</i>	Tengakotra
13.	<i>Barringtoniaacutangula</i>	Hijal
14.	<i>Bombax malabarica</i>	Simalu
15.	<i>Carallia lucida</i>	Mohithekara
16.	<i>Callicarpa arborea</i>	Maskiita
17.	<i>Caseariaglomerata</i>	Telbhurukia
18.	<i>Cassia fistula</i>	Sonam
19.	<i>Celtistimorensis</i>	Mahila
20.	<i>Cordia dichotoma</i>	Ghapakharea
21.	<i>Craetera religiosa</i>	Barun
22.	<i>Croton oblongifolius</i>	Makhunda
23.	<i>Callistemon linearis</i>	Bottle brush
24.	<i>Canariumbengalensis</i>	Dhuna
25.	<i>Canarium strictum</i>	Dhuna
26.	<i>Cassia javanica</i>	Malayan cassia
27.	<i>Chrysophyllus lanceolatum</i>	Bon pitha
28.	<i>Celbapentandra</i>	White silk cotton
29.	<i>Cinnamomumcamophora</i>	Karpur
30.	<i>Cordia sebestina</i>	Lolu
31.	<i>Anthocephaluschinensis</i>	Kodam

Assam Skill University Project
Initial Environmental Examination for Boundary Wall Construction

Sl. No.	Scientific Name	Common Name
32.	<i>Artocarpuschama</i>	Chamkathal
33.	<i>Artocarpusintegrifolia</i>	Kathal
34.	<i>Acacia auriculiformis</i>	Akasmani
35.	<i>Acacia catechu</i>	Khair
36.	<i>Crescentia cujete</i>	Bilatibel
37.	<i>Caesalpiniapulcherina</i>	Radhasurea
38.	<i>Dalbergia sissoo</i>	Sisu
39.	<i>Derris robusta</i>	Kothriakorai
40.	<i>Dilleniaindica</i>	Outenga
41.	<i>Dilleniascabrella</i>	Banjole
42.	<i>Diospyros variegata</i>	Koliori
43.	<i>Dysoxylumbinectariferum</i>	Bandardima
44.	<i>Dalbergialatifolia</i>	Rose wood
45.	<i>Dipterocarpus retusus</i>	Holang
46.	<i>Ehretiaacuinata</i>	Gual
47.	<i>Erythrina stricta</i>	Modre
48.	<i>Eugenia balsamea</i>	Goolhajam
49.	<i>Elaeocarpus floribundus</i>	Jalpai
50.	<i>E. ganitrus</i>	Rudrakesha
51.	<i>Eucalyptus tereticornis</i>	Red gum
52.	<i>E. globules</i>	Blue gum
53.	<i>E. citriodora</i>	Lemon scented
54.	<i>Exbucklandiapopulnea</i>	Diengdok
55.	<i>Ficusbengalensis</i>	Bot
56.	<i>F. benjamina</i>	Joribor
57.	<i>F. elastica</i>	Athabor, Indian
58.	<i>F. hispida</i>	Dimoru
59.	<i>F. religiosa</i>	Ahat
60.	<i>F. cunia</i>	Kongroy
61.	<i>Flacourtiajongomus</i>	Poniyal
62.	<i>Garcinia cowa</i>	Kujithekera
63.	<i>G. pedunculata</i>	Borthekera
64.	<i>G. xanthochymus</i>	Tepontenga
65.	<i>Gliricidasepium</i>	Madera
66.	<i>Garugapinnata</i>	Rohini
67.	<i>Glochidionlancedarum</i>	Armlochan
68.	<i>Glochiolionsphaerogynum</i>	Bob Jagru
69.	<i>Magnolia griffithii</i>	Gahorisopa
70.	<i>Machilusbombycina</i>	Som
71.	<i>Manilkarahexandra</i>	Oubard
72.	<i>Mesuaferrea</i>	Nahae

Assam Skill University Project
Initial Environmental Examination for Boundary Wall Construction

Sl. No.	Scientific Name	Common Name
73.	<i>Melia azedarch</i>	Ghoranim
74.	<i>Memelyloncerasiforma</i>	Kakoichera
75.	<i>Micheliachampaca</i>	Titasopa
76.	<i>M. oblonga</i>	Phulsopa
77.	<i>M. montana</i>	Phulsopa
78.	<i>Mimusopselongi</i>	Bakul
79.	<i>Morus macroura</i>	Bola
80.	<i>Moringa oleifera</i>	Sajina
81.	<i>Myristicakingii</i>	Amol
82.	<i>Mallotusferrugineus</i>	Larubandha
83.	<i>Mangiferaindica</i>	Am (Mango)
84.	<i>Micromelumminutum</i>	Sagladi
85.	<i>Nyctanthesarbortristis</i>	Sewali
86.	<i>Oroxylumindicum</i>	Bhatghila
87.	<i>Premhalatifolia</i>	Gonara
88.	<i>Palaquimpolyanthum</i>	Kurta
89.	<i>Pongamiapinrata</i>	Tamsica
90.	<i>Phoebe goalparensis</i>	Bonscn
91.	<i>Polyalthialongifolia</i>	Debdaru
92.	<i>P. pendula</i>	Pendulum tree
93.	<i>Psidium guajara</i>	Madhuriam
94.	<i>Putrajivaroxburghii</i>	Putranjibi
95.	<i>Phyllanthus emblica</i>	Amlakhi
96.	<i>Sapiumbaccatum</i>	Cheleng
97.	<i>Semecarpus anacardium</i>	Bhela
98.	<i>Syzygiumcumini</i>	Kalajam
99.	<i>Shorearobusta</i>	Sal
100.	<i>Spathodeacampanulata</i>	Fountain tree
101.	<i>Spondiuspinnata</i>	Amorea
102.	<i>Swietenia macrophylla</i>	Mahogeni
103.	<i>S. mahagoni</i>	Mahogeni
104.	<i>Santalum album</i>	Chanolan
105.	<i>Talaumahodgsonii</i>	Bovehamthuri
106.	<i>Tectonagrandis</i>	Segun
107.	<i>Terminalia chebula</i>	Silikka
108.	<i>T Arjuna</i>	Arjun
109.	<i>T. belerica</i>	Bhoora

32. The fauna in the surroundings of ASU site includes Wild Boar, Jungle Cat, Asiatic Jackal, Bengal Fox, Small Indian Civet, Indian Grey Mongoose, Small Asian Mongoose, Rhesus Macaque, Assam Macaque, Capped Langur, Bengal Slow Loris, Indian Palm Squirrel, Porcupine, Lesser Bandicoot Rat, Hoary Bamboo Rat, Indian flying Fox, short nosed Indian fruit Bat, Least horseshoe Bat. The reptiles include Tree frog, Ornamented

Pygmy, Indian bull frog, Common Pond Frog, Water frog, Common Rat Snake, North-eastern Kukri, Golden Tree Snake, Banded Krait, Indian Roofed Turtle, Indian Soft Shell, Peacock, etc. The common avian in the project ASU site and surroundings are Little grebe, Little cormorant, Grey Heron, Pond Heron, Smaller egret, Little egret, Stork, Lesser adjutant stork, Large whistling teal, Pintail, Common teal, Pariah kite, White backed vulture, Pied Harrier, Crested Serpent eagle Coot, Common Sand piper, Spotted dove, The cuckoo, Koel, Spotted owlet, Common kingfisher, Copper smith, Pied wood pecker.

33. There are no endangered or rare species fauna as project site is located close to Mangaldoi town. At the site and surroundings, there are no endangered species of flora also.

34. The water bodies around ASU site are seasonal in nature. There is not much presence of aquatic life in the water bodies close to the site as these are shall ponds/low lying areas, which get dried up in winter and summer months. The site is surrounded by open agriculture land and sparse habitation.

(iii) Protected Areas

35. The list of protected areas (National Parks and Wildlife Sanctuaries) in Assam is given in **Table 7**. In Darrang district, there is part of Orang National Park But the boundary of National Park is about 38 km. The map of protected areas is shown in **Figure-7**.

**Table-7: Protected Areas in Assam
(a) National Parks**

Name	Location	Area (km²)	Year of Notification
<u>Kaziranga National Park</u>	<u>Golaghat, Nagaon district and Karbi Anglong</u>	858.98	1905
<u>Manas National Park</u>	<u>Kokrajhar, Chirang, Baksa, Bajali, Udalguri, and Darrang</u>	950.00	1985
<u>Nameri National Park</u>	<u>Sonitpur</u>	200.00	1978
<u>Dibru-Saikhowa National Park</u>	<u>Dibrugarh and Tinsukia district</u>	340.00	1978
<u>Orang National Park</u>	<u>Darrang, Udalguri and Sonitpur district</u>	78.81	1999
<u>DehingPatkai National Park</u>	<u>Dibrugarh and Tinsukia district</u>	231.65	2020

(b) Wildlife Sanctuaries

Name	Location	Area (km²)	Year of Notification
<u>Hoollongapar Gibbon Sanctuary</u>	<u>Jorhat</u>	20.98	
<u>Garampani Wildlife Sanctuary</u>	<u>Karbi Anglong</u>	6.05	
<u>Bura Chapori Wildlife Sanctuary</u>	<u>Sonitpur</u>	44.06	
<u>Bornadi Wildlife Sanctuary</u>	<u>Udalguri</u>	26.22	1980
<u>SonaiRupai Wildlife Sanctuary</u>	<u>Sonitpur</u>	220.00	1998
<u>Pobitora Wildlife Sanctuary</u>	<u>Marigaon</u>	38.80	1987
<u>Panidihing Bird Sanctuary</u>	<u>Sibsagar</u>	33.93	
<u>Bherjan-Borajan-Padumoni Wildlife Sanctuary</u>	<u>Tinsukia</u>	7.22	
<u>Nambor Wildlife Sanctuary</u>	<u>Karbi Anglong</u>	37.00	
<u>East Karbi-Anglong Wildlife Sanctuary</u>	<u>Karbi Anglong</u>	222.81	

<u>Laokhowa Wildlife Sanctuary</u>	<u>Nagaon</u>	70.13	
<u>Chakrashila Wildlife Sanctuary</u>	<u>Dhubri and Kokrajhar</u>	45.57	
<u>Marat Longri Wildlife Sanctuary</u>	<u>Karbi Anglong</u>	451.00	
<u>Nambor-Doigrung Wildlife Sanctuary</u>	<u>Golaghat</u>	97.15	
<u>DehingPatkai Wildlife Sanctuary</u>	<u>Dibrugarh and Tinsukia</u>	111.19	
<u>Borail Wildlife Sanctuary</u>	<u>Cachar and Dima Hasao</u>	326.25	
<u>Amsang Wildlife Sanctuary</u>	<u>Guwahati</u>	78.64	
<u>Dipor Bil Wildlife Sanctuary</u>	<u>Kamrup</u>	4.14	

Source: Department of Environment and Forest, Govt. of Assam, Year 2020)

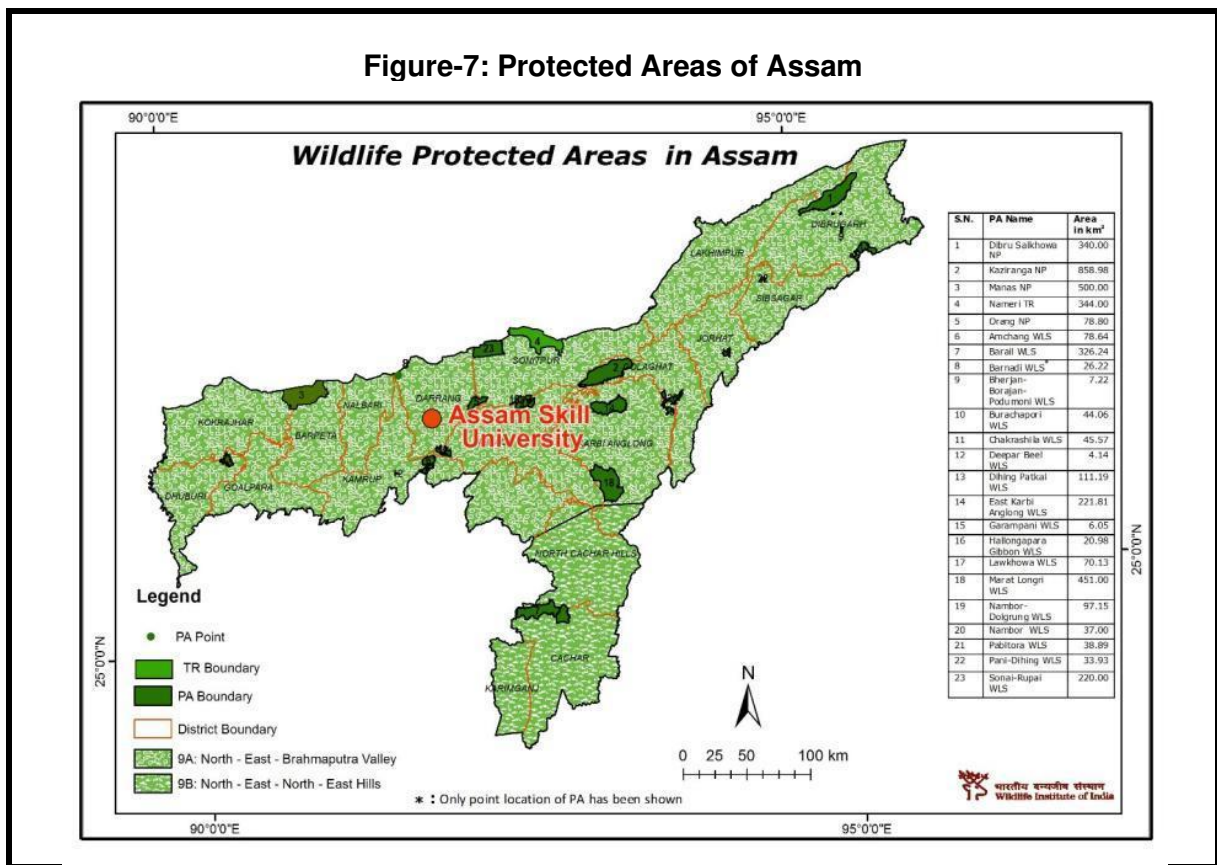

Source: Department of Environment and Forest, Govt. of Assam, Year 2020)

C. Economic Resources Industries

36. Being an agriculture prominent district, there are no large industrial units in the Mangaldoi and surroundings. As shown in **Table-8** for Darrang district, there are micro, small, and medium enterprises focusing on agro-products, food, cotton textiles, etc.

Table-8: Details of Existing Micro and Small Enterprises and Artisan Units in Darrang District

NIC Code No	Type of Industry	Number of Units	Employment
10	Manufacture of Food Products	43	1917
11	Manufacture Beverages	1	10
13	Manufacture of Textiles	3	95

NIC Code No	Type of Industry	Number of Units	Employment
17	Manufacture of Paper and Paper Products	3	47
20	Agro based	1	10
22	Soda water	4	36
23	Cotton textile	34	623
24	Woolen, silk & artificial Thread based clothes.	1	15
25.	Jute & jute based	-	-
26.	Ready-made garments & embroidery	-	-
27.	Wood/wooden based furniture	1	10
28.	Paper & Paper products	-	-
31.	Chemical/Chemical based	1	10

Source: Statistical Handbook of Assam (Year 2016)

Transportation

37. The ASU site is well connected with Guwahati, West Bengal and other states of north eastern region of the country through various national highways and state highways. The nearest rail head is Darrang at about 5 km from ASU site. The nearest operating airport is Guwahati from the ASU site and its distance is about 74 km. No clearance or permission from Airport Authority of India (AAI) is needed for the construction of boundary wall and other components of the ASU.

Land Use

38. A study of the land use (**Table-9**) shows that majority of the area in Darrang district is under agriculture and none agriculture use. It is also clear that forest land and waste land is not significant. The land use of ASU site is rural open land. If land use of ASU site is to be seen in terms of classification of **Tables 9**, it will fall 'Land put to non agriculture uses'.

Table-9: Land Use Pattern of Darrang District

Land use	Area (In 000' hectare)
Geographical Area	158.5
Forest land	10.541
Culturable Waste land	3.879
Land put to None Agriculture Uses	97.319
Gross Cropped Area	132.670
Net Area Sown	73.319
Area Sown more than Once	59.351

Source: District Irrigation Plan 2016-2020 for Darrang District

39. **Agricultural Development.** Darrang district is basically agrarian, where more than 65 percent of the population is engaged in agriculture and allied activities Agriculture in Darrang is characterized by small holdings operated by family labor, both men & women. Average land holding size in Darrang is 0.95 ha. However, small & marginal farmers & Landless, who make up 89 % of land holders, have an average farm size of 0.57 ha. Fruits and cash crops are a major source of income. Paddy is the principal crop grown in the district and autumn paddy, winter paddy and summer paddy are the three main types of paddy are grown in the district. Next to paddy, wheat, rapeseed and mustard, sugarcane and

vegetables are the main agricultural produce. Among cash crops Jute accounted for 3.2 % and Sugarcane 0.38 % of the total cropped area.

Electrification

40. The Rural Electrification in Darrang district is 100%.

D. Social and Cultural Resources

Population and Communities

41. As per 2011 census, the total population of Darrang was 928500, with density of population 586 per sq. km, which is higher than the state average of 398. The decadal variation of population for 2001-2011 was 22.19 percent, which had experienced much higher decadal variations during last several decades. Witnessing quite a sluggish process of urbanization, the overwhelming majority of people in Darrang live in the villages. The district is predominantly rural with more than 94 per cent of the total population in the district is residing in rural area while the urban population is 5.98 percent which is lower than the state average of 14.1 percent. In terms of religious composition, around 58 per cent of the total population in the district is Hindu while the Muslim constitutes more than 35 per cent of the total population. Almost all the Muslims live in the rural areas, while around 4 percent of the Hindus live in urban areas. The other minority communities constitute less than six per cent of the total population of the district. In the district, Dalgaon Revenue Circle is the most populous having 473585 persons while Khoirabari is the least populous Revenue Circle having 8398 persons. Darrang district is basically agrarian, where more than 65 percent of the population is engaged in agriculture and allied activities. Out of the total population, 39.85 percent population was involved in agriculture as a main source of income and livelihood. Around 25 percent of the total population had agricultural laborers. Moreover, males were predominantly involved in agriculture and allied activities with 43.60 percent while women share was 27.97 percent of the total population of district. However, women were overwhelmingly in manufacturing and production in household, small scale industry, rearing of livestock and collection of forest woods etc. Like elsewhere, women are also engaged in agricultural labor.

Health facilities

42. Darrang district has one civil hospital, 30 Primary Health Centers, 1 First Referral Unit, 6 Community Health Centers, and 163 Sub Centers of Community Health Centers. In addition to above mentioned government run health facilities, there are many privately owned facilities available in major urban centers of the district.

Education facilities

43. In Darrang district there are 1096 primary schools, 154 Middle Schools, 1656 Senior Secondary Schools and 18 colleges. There are many technical education training institutes. The current ASU project will also contribute towards skills development and employability of youth from the Assam and North Eastern states.

Archaeological Resources

44. There are no heritage sites notified by Archaeological Survey of India (ASI) within 300 m distance from the ASU site. Similarly, no common property resources such as public wells, water tanks, play grounds, common grassing grounds or pastures, market areas and community buildings exist at the ASU site.

IV. ENVIRONMENTAL IMPACT AND MITIGATION MEASURES

A. Environmental Impacts

45. Any project creating physical infrastructure will cause some minor impacts on the environment. This IEE examines the potential impacts anticipated during the construction and operation phases due to construction of boundary wall at the ASU site:

- (i) **Location impacts:** Impact associated with site of the project including effect on the environment and resettlement or livelihood related impacts on communities;
- (ii) **Design impacts and pre-construction impacts:** Impact arising from project design, including the technology used, scale of operations, discharge standards, topographic survey, geotechnical survey, etc.;
- (iii) **Construction impacts:** Impact resulting from construction activities including site clearance, earthworks, civil works, etc.; and
- (iv) **Maintenance impacts:** Impact associated with the maintenance of the boundary wall of ASU project.

46. ADB's REA checklist for Buildings was used while screening the site and location of boundary wall of ASU and recommending mitigation measures.

B. Location Impacts

47. The ASU site is located on unencumbered land owned by ASDM, GoA. The boundary wall construction will be on edge of plot (**Annexure- 3**). There are no significant ecological resources in the surroundings of ASU site as it is lying vacant and is close to habitation area of Mangaldoi town. There are no heritage sites notified by ASI or State Archaeological Department within the delineated site or in the immediate surroundings (300 m distance). No significant impacts can arise due to ASU location as its components including boundary wall will not impinge upon any area of ecological, archaeological or historical importance. The ASU site is not in the immediate vicinity of national highway or state highway. The distance of National Highway -15 (connecting Guwahati and Mangaldoi) is about 1 km, so air and noise pollution impacts on ASU are not anticipated on account of vehicular traffic.

48. The ASU site is located within seismic zone V and even a small magnitude earthquake may damage boundary wall and buildings of ASU.

C. Impacts during Design and Pre-Construction Phase

49. As noted above, the proposed project site of ASU is owned by ASDM, GoA. There are no issues pertaining to tree cutting. Based on the environmental screening of the ASU site, it is concluded that there are no significant adverse environmental impacts during the design and boundary wall construction phase of project.

D. Impacts during Construction Phase

50. All construction activities to be undertaken at the ASU site for the construction of boundary wall will be approved by the PMU at the ASDM. The construction stage impacts due to the proposed project components are generic to the construction activities. The EMP emphasizes on the construction impacts and necessary mitigation measures to be strictly followed by the contractor and supervised by the PMU or authorized agency appointed (PMC) by the ASDM. The key potential impacts are covered in the following paragraphs.

51. **Impact due to stockpiles of construction materials.** Improper stockpiling of construction materials could obstruct movement of locals accessing agriculture fields in the surroundings of site. Hence, due consideration will be given for proper materials storage at construction site. Stockpiles will be covered to protect from dust and erosion.

52. **Disposal of construction waste.** The construction waste could lead to untidy conditions at site and surroundings. These wastes will comprise broken pieces of bricks and surplus earth. In the boundary wall construction, it shall be mandatory for the contractor to ensure proper disposal of the construction waste at the disposal site as designated by the PMU of ASDM.

53. **Quarry and Borrow pits operations.** Since the civil works are of a small size, all construction material will be procured from market/ sources compliant with the environmental regulations of India. There will not be any need for direct procurement of stone dust and sand and other building materials from quarries.

54. **Increase in noise levels.** Noise levels in the immediate proximity of boundary wall construction site are expected to increase somewhat during construction. However, these will be largely imperceptible as civil works will be confined to relatively small area. There are no houses in the immediate vicinity of the site. The distance of nearest house is about 50 m from the boundary. The duration of construction will also be relatively brief. Transportation of construction materials will be confined to daytime, depending upon extent of construction activity. The increase in noise levels is expected to be between 3-5 dB (A). This increase will be felt up to a distance of 100-200 m only. This noise will be intermittent in nature, and will last only during the construction phase. The construction noise will not be felt as there is no habitation within in the vicinity. But necessary monitoring of noise levels will be taken up as part of environmental monitoring plan.

55. **Impacts on biodiversity during construction phase.** No major impacts are expected on the biodiversity during the construction phase boundary wall as the ASU site is in an open area. There are no endangered or rare species of flora and fauna in the surroundings of proposed ASU site.

56. **Disturbance due to traffic during construction phase.** At the time of construction, inconvenience to locals is not anticipated as site is accessible through a wide road and away from habitation. Traffic on the connecting road to the ASU site from NH-15 is almost insignificant. However, a sample Traffic Management plan is attached in **Annexure- 3**.

57. **Impact on cultural properties.** The boundary wall construction for the proposed ASU site will not have any impact on any religious structure or any other structure of historical and/or cultural significance.

58. **Ground Water.** Ground water will not be extracted and used for construction purposes. The contractor will arrange for water from the market. It will be supplied by the authorized water tankers. The problem of ground water contamination is also not anticipated during the construction phase since there will be proper disposal of the wastewater generated from the construction camp.

59. **Ambient Air Quality.** Generation of dust is anticipated during transportation, excavation, and construction activities. Some dust and gaseous emissions will also be generated during the construction period from machines such as mixers, and vehicles engaged in transportation of construction materials. Pollutants of primary concern at this stage include respirable and suspended particulate matter (RSPM) and gaseous emissions (NO_x, SO₂, CO, etc.). However, transportation of construction materials will be confined to a few trips per day depending upon extent of construction activity. Therefore, impact at this

stage will be temporary and restricted to the close vicinity of the construction site only.

60. All vehicles and construction equipment operating for the contractor and the PMU ASDM will obtain and maintain "Pollution under Control" (PUC) certificates. To control dust emissions, vehicles deployed for borrow materials, sand and aggregate haulage, will be covered with tarpaulins to prevent spillage. Regular sprinkling of water during excavations, loading, unloading, vehicular movement, and raw material transport will prevent spread of dust and other contaminants. Periodic air quality monitoring will be conducted to ensure that emissions comply with the vehicle emission standards specified by the GoI and ambient air quality standards specified by the Central Pollution Control Board. The contractor will submit emission monitoring results as a compliance with environmental monitoring plan. The impacts related to air pollution on account of construction activities will be felt close to ASU site.

61. **Construction Waste.** Some waste will be generated due to excavated earth material and waste from construction. Debris and excavated earth material can be reused subject to the approval of the Engineer during the construction. Waste generated during construction and demolition will be disposed off as per law and to the satisfaction of the Engineer. The clean-up and restoration operations will be implemented by the contractor prior to demobilization. The contractor will clear all temporary structures and dispose off all garbage from project site. Entire construction site and surrounding vacant area will be left tidy, at the contractors' expense as per the satisfaction of the Engineer.

62. The contractor is likely to engage local labor for various construction activities. However, in case of migrant labor has to be engaged, the contractor will establish properly designed labor camp with all basic amenities such as potable water supply and sanitation facilities (septic tanks and soak pit). Dust bins will be placed in adequate numbers. The EMP lays down some measures to address likely adverse impacts associated with the labor camps.

63. **Occupational Health and Safety and COVID-19.** The occupational health and safety related impacts will include injury to the construction work force, chances of more accidents at site and adverse impacts on health of workers if proper measures are not adopted and necessary protection gadgets are not provided. COVID-19 related impacts will cause chances of infections more if protection measures are not provided.

E. Environmental Impacts during Operation Phase

64. In the current Boundary wall component of ASU only boundary wall construction is planned. In the operation phase, there will be only minor repairs if there is any damage to the wall. Hence environmental impacts are not anticipated due to this boundary wall construction. Necessary cross drainage features have been included in the boundary wall design.

65. **Safety Measures.** The design of boundary wall includes structural and seismic safety measures required by India's latest building codes (in seismic zone V).

66. **Socioeconomic Impacts.** The sub-project of boundary wall construction will not have any socio-economic impact. But the ASU project functioning will have a positive socio-economic impact since it will provide youth and adults an opportunity to enhance job-oriented skills.

67. **Flora and Fauna.** The boundary wall construction is on the land owned by the GoA for the project. In the absence of any trees or vegetation, no adverse impact on fauna and flora is anticipated. No tree cutting is required. Further, in the ASU campus, plantation of shrubs and landscaping will be taken up along the pathways and vacant spaces to enhance

natural ambience. There is no existence of any wildlife/bird sanctuary, national park or any other area notified by the GoA or MoEFCC for ecological importance within an aerial distance of 15 km from the ASU site.

68. **Emergency Plan for Accident and Natural Hazards.** For operation phase onsite emergency plan will be prepared by the ASU. For natural calamities, the Disaster Management Plan prepared by GoA for Darrang district will be followed. The GoA has prepared district wise Disaster Management Plans as per provisions of Disaster Management Act 2005 of Government of India.

F. Description of Planned Mitigation Measures

69. Screening of environmental impacts is based on the magnitude and duration of the impact. **Table-10** provides the potential environmental impacts and the mitigation measures including the institutional responsibilities for implementing the same. The sub-project site is located sufficiently away from protected areas and the components proposed will not impact any environmentally sensitive or protected areas. All sub-project activities including construction and operation will take place within available government land.

Table-10: Summary of Environmental Impacts and Planned Mitigation Measures

Sl. No.	Potential Environmental Issues	Duration or Extent	Magnitude	Proposed Mitigation Measures	Institutional Responsibilities
1	Location Impacts				
1.1	Lack of sufficient planning to assure long term sustainability of the boundary wall and ensure protection specially from earthquake and other natural disasters	Permanent	Major	The design of boundary wall has been completed considering earthquake coefficient of zone V.	PMU
2	Design and Pre-construction Impacts				
2.1	Consents, permits, clearances, no objection certificates (NOC), etc.	Permanent	Minor	Obtain all necessary consents, permits, clearance, NOCs, etc. prior to start of civil works. Acknowledge in writing and provide report on compliance with all the obtained consents, permits, clearance, NOCs, etc. Include in detailed design drawings and documents all conditions and provisions, if necessary.	PMU site office
2.2	Layout of components to avoid impact on the aesthetics of the ASU site	Permanent	Minor	The boundary wall will not have any adverse impacts on aesthetics of site as there will be only erection of boundary wall and exteriors of boundary wall will be similar to the exteriors of buildings in the project region.	Not Applicable
2.3	Increased storm water runoff from alterations of the site's natural drainage patterns due to landscaping, excavation works, construction of parking lots, and addition of paved surface.	Permanent	Minor	The boundary wall construction will not increase any significant paved surface. But subsequent layout finalization and design of ASU will take care of site storm water runoff quick disposal.	Not Applicable
2.4	Integration of energy efficiency and energy conservation programs in design of boundary wall	Permanent	Moderate	No mitigation measures warranted as boundary wall is a minor construction. But for lighting for the security will adopt following measures:	PMU

SI. No.	Potential Environmental Issues	Duration or Extent	Magnitude	Proposed Mitigation Measures	Institutional Responsibilities
				<ul style="list-style-type: none"> Installation of BEE certified equipment at the entrance gate for handling movement to and from the site Usage of energy efficient lighting fixtures (LED and solar) 	
2.5	Impacts on flora and fauna	Permanent	Minor	The construction of boundary wall does not require cutting of trees. There may be requirement for removal of locally grown shrubs. This loss of shrubs will be made up during landscaping works of the ASU in the subsequent construction packages of the project.	PMU
3	Construction Impacts				
3.1	Construction camps - location, selection, design and layouts	Temporary	Moderate	Construction camp, if established, at the ASU site will be located within the ASU plot. The construction camp will not affect the day-to-day activities of local residents as workforce will not exceed 15. Adequate sanitation facilities shall be provided at camp site and no wastewater will be discharged outside.	Contractor and PMU
3.2	Traffic circulation plan during construction	Temporary	Minor	<p>Prior to commencement of site activities and mobilization on ground, the contractor will prepare a traffic circulation plan for safe passage of local traffic during construction stage. This will include alternative access routes, traffic regulations, Signages, etc. The contractor will get these plans approved from the PMU from the traffic police with the assistance of PMU Site Team.</p> <p>The contractor will disseminate the traffic circulation plan around the project site.</p>	Contractor and PMU
3.3	Impacts on flora and fauna	Temporary	Minor	The PMU will conduct site induction and environmental awareness program for the construction workers and site supervising team	Contractor and PMU

**Assam Skill University Project
Initial Environmental Examination for Boundary Wall Construction**

SI. No.	Potential Environmental Issues	Duration or Extent	Magnitude	Proposed Mitigation Measures	Institutional Responsibilities
				at the site. The construction related activities will be limited within the site of ASU. Storage of construction materials will be within the project site limits.	
3.4	Clearance activities, including delineation of construction corridor of boundary wall	Temporary	Moderate	The commencement of clearance activities for the boundary wall construction will be undertaken with due permission from the environment specialist of the PMU to minimize environmental impacts. All areas used for temporary construction operations will be subject to complete restoration to their former conditions with appropriate rehabilitation procedures.	Contractor and PMU
3.5	Drinking water availability	Temporary	Major	Sufficient supply of potable water will be provided and maintained at the construction site and construction camp. If the drinking water is obtained from an intermittent public water supply, then storage tanks will be provided.	Contractor and PMU
3.6	Waste disposal	Permanent	Major	Location of disposal site for construction waste will be finalized by the environmental specialist of the PMU. The PMU will confirm that disposal of the material will not impact the water body or environmentally sensitive areas.	Contractor and PMU
3.7	Stockpiling of construction materials	Temporary	Moderate	Stockpiling of construction materials should not impact or obstruct the local drainage and stockpiles will be covered to protect from dust and erosion.	Contractor and PMU
3.9	Soil and Water Pollution due to fuel and lubricants, construction waste	Temporary	Moderate	The fuel storage and vehicle cleaning area at site should be avoided as far as possible. In case of unavoidable circumstances, fuel storage should be in the leak proof drums and storage of drums should be on temporary raised paved platform.	Contractor and PMU
3.10	Generation of dust	Temporary	Moderate	The contractor will take every precaution to	Contractor and PMU

**Assam Skill University Project
Initial Environmental Examination for Boundary Wall Construction**

Sl. No.	Potential Environmental Issues	Duration or Extent	Magnitude	Proposed Mitigation Measures	Institutional Responsibilities
				reduce the levels of dust at construction site. The site will be properly barricaded with prefabricated MS sheets.	
3.11	Emission from construction vehicles, equipment and machinery	Temporary	Moderate	Vehicles, equipment and machinery used for construction will conform to the relevant standards (vehicular emission standards of Gol and CPCB specified standards for equipment and machinery) and will be regularly maintained to ensure that pollution emission levels comply with the relevant requirements.	Contractor and PMU
3.12	Noise pollution	Temporary	Moderate	Noise limits for construction equipment used in this project will not exceed 75 dB (A).	Contractor and PMU
3.13	Material handling at site	Temporary	Moderate	Workers employed on mixing cement, lime mortars, concrete, etc., will be provided with protective footwear and protective goggles. Workers, who are engaged in welding works, will be provided with welder's protective eye-shields.	Contractor and PMU
3.14	Disposal of construction waste	Temporary	Moderate	Safe disposal of the construction waste will be ensured in the pre-identified disposal locations. In no case, any construction waste will be disposed off around the sub-project site and especially in vacant plots in the locality.	Contractor and PMU
3.15	Occupational Health and Safety and COVID-19 measures during construction	Temporary	Moderate	Adequate safety measures for workers during handling of materials at the ASU site will be taken up. The contractor has to comply with all regulations for the occupational safety of workers. Precaution will be taken to prevent danger of the workers from fire, accidental injury, etc. First aid treatment will be made available for all injuries likely to be sustained during the course of work. The Contractor will comply with all anti-malaria	Contractor and PMU

Sl. No.	Potential Environmental Issues	Duration or Extent	Magnitude	Proposed Mitigation Measures	Institutional Responsibilities
				instructions/advisories given by the PMU or engineer appointed by ASDM. All protection measures pertaining to COVID-19 will be taken at the site. For this a COVID-19 Health and safety Plan will be prepared by the contractor after mobilization.	
3.16	Clearing of construction of camps and restoration	Temporary	Major	Contractor at the ASU site will prepare site restoration plan for approval by the PMU/Engineer. These camp site restoration plans are to be implemented by the contractor prior to demobilization. On completion of the works, all temporary structures will be cleared away, all rubbish burnt, excreta or other disposal pits or trenches filled in and effectively sealed off and the site left clean and tidy, at the contractor's expense, to the entire satisfaction of the engineer.	Contractor and PMU
3.17	Onsite emergency plan for minor accidents and mishaps and Disaster Management Plan for Natural Calamities	Temporary	Major in case of natural calamity and minor in case of accidents or mishaps at construction site	The onsite emergency plan will be prepared by the contractor in consultation with PMU. For natural calamities, disaster management plan prepared by the Darrang District Administration under the provisions of Disaster Management Act 2005 will be followed.	Contractor
4	Operation and Maintenance impacts				
4.1	Safety risks	Temporary	Moderate	The boundary wall will be well maintained and manned for the security of ASU.	ASDM
4.2	Unhygienic conditions due to poor maintenance of sanitation facilities at entrance gate and irregular solid waste collection	Temporary	Severe	The ASU Management will carry out maintenance of the toilets at the entrance gates, and carry out the regular waste collection from gate office and disposal of the waste to the local disposal site. The septic tanks will be maintained and emptied regularly.	ASDM
4.3	Onsite emergency plan for minor accidents and mishaps and Disaster Management	Temporary	Major in case of natural calamity and minor in case	The Management Team of ASU will prepare on site emergency plan for possible minor accidents and mishaps during operation phase.	Head ASU

**Assam Skill University Project
Initial Environmental Examination for Boundary Wall Construction**

Sl. No.	Potential Environmental Issues	Duration or Extent	Magnitude	Proposed Mitigation Measures	Institutional Responsibilities
	Plan for Natural Calamities		of accidents or mishaps at ASU	For natural calamities, the disaster management plan prepared by Darrang district administration will be followed.	

G. Land Aquisition and Resettlement

70. The proposed ASU is planned on the land owned by ASDM, GoA. The boundary wall construction is being taken up on the external limits of plot. The revenue records showing ownership of GOA for the project site have been given in **Annexure-3**. Hence, there will not be any acquisition of private land. The proposed plot for ASU development is unencumbered Government land; therefore, there are also no squatters or encroachers. Hence, there is no requirement of any rehabilitation and resettlement for constructing boundary wall and subsequently ASU facilities and infrastructure.

V. ANALYSIS OF ALTERNATIVES

71. The construction of the boundary wall forms part of a bigger subproject which involves construction of several school buildings within a 100 acre land. A 'no subproject' scenario would mean that the construction site would be open to the public and may pose security threats and community safety risks during construction and operational phases. The 'with subproject' scenario will enclose the area through a physical barrier which will prevent outsiders from unauthorized access to the university premises. The subproject location was carefully planned so that no significant ecological resources, no significant heritage sites and no sensitive receptors would be affected in constructing the boundary wall. The boundary wall is also planned to be constructed within an encumbered land owned by ASDM, GoA. In terms of design, materials will be appropriately selected considering that the area is within the seismic zone V classification. Energy efficient lighting fixtures will also be installed for added security. While the 'with subproject scenario' may have negative environmental impacts from construction activities, the environmental impacts are projected to be temporary and short-term in nature. The impacts during construction and mitigation phase are not adverse and can be readily mitigated.

VI. ENVIRONMENT MANAGEMENT PLAN (EMP)

A. Institutional Arrangements for Project Implementation

72. The Government of Assam through Skill, Employment, and Entrepreneurship Department (SEED) is the executing agency (EA). The EA (i) assumes overall responsibility for the execution of the project and reporting; (ii) engages adequate permanent or fixed-term staff to implement the Project; (iii) provides overall strategic guidance on technical supervision and project execution; and (iv) ensures overall compliance with the loan covenants.

73. The implementing agency (IA) for the project is ASDM. The ASDM is registered under the Societies Act. The IA responsibilities include (i) project planning and budgeting; (ii) day-to-day assistance, supervision and guidance for the project site team and consultant; (iii) review ASU components for due diligence requirements and approve sub-project proposals; (iv) bidding, evaluation and contract award; (v) managing and disbursing funds; (vi) review compliance with loan covenants, contract specifications, work plans and quality control; (vii) monitoring and reporting of environmental safeguards and (viii) consolidate and submit progress reports, finance and accounting / audit reports, and matters requiring higher level decision to project steering committee (PSC) and ADB.

74. In Assam, a state level PSC has been established. This committee is chaired by Secretary SEED, with secretaries of industry, agriculture, land and revenue, information technology, health, planning and finance, handloom and textile, tourism, transformation and development, education, public works, social justice and empowerment, and the vice chancellor of ASU as members. The PSC has been empowered to take all decisions on behalf of the State and will (i) act as a policy making body, (ii) provide overall advice and guidance to the State's EA and PMU, and (iii) accord all approvals under the project.

75. The ASDM has established a PMU, headed by a full-time Project Director (PD) at ASDM, and consisting of personnel drawn from relevant line departments and market. This PMU will also have safeguards expert (social and environment). The PMU will be supported by the project management consultants (PMC). The PMU will be the nodal agency for overall management of all project activities and will be responsible for: (i) project planning and budgeting; (ii) providing day-to-day assistance, supervision and guidance for the site team, contractors and consultants; (iii) reviewing ASU components to satisfy ADB's due diligence requirements and approving proposals submitted by contractors and site team of PMU; (iv) bidding, evaluation and contract award; (v) managing and disbursing funds; (vi) reviewing compliance with loan covenants, contract specifications, work plans and quality control; (vii) monitoring and reporting of environmental safeguards; (viii) consolidating and submitting progress reports, finance and accounting/audit reports, and matters requiring higher-level decision, to the PSC and ADB; and (ix) formation and deputation of PMU site team at Mangaldoi for quality check, construction works supervision, safeguard compliances during construction and maintaining schedule of construction pace for timely completion.

76. The ASU boundary wall construction will be implemented by the site team of PMU. The site team will have personnel drawn from relevant line departments on deputation and outside of government and will be headed by a Project Manager/Site In charge. This site team for the ASU boundary wall sub-project will be responsible for: (i) prioritizing and preparing sub-project proposals; (ii) providing day-to-day assistance, supervision and guidance to the contractor; (iii) conducting detailed assessments and surveys including public consultation and input from stakeholders; (iv) preparing detailed designs, specifications, schedule of quantity, bidding documents, and related documentation; (v) implementing civil works and related activities; (vi) reporting to PMU; (vii) preparing regular

progress reports for the PSC, the executing agency and ADB through PMU; (viii) compliance with safeguards requirements with the guidance from PMU safeguards specialists(viii) supervising construction, conducting quality control, approving progress payments to contractors; and (ix) maintaining records and accounts on an up-to-date basis and making these available to ADB, its missions, or auditors for inspection.

77. The Project management consultant (PMC) will be engaged to provide support to the PMU in overall planning, risk management, implementation, monitoring and evaluation of sub-projects under the project. The PMC will assist the PMU and site team in meeting the relevant requirements of ADB, GoA, and Gol for project implementation. The PMC team will report and work under the overall guidance of the PMU. The scope of services of the PMC's include: (i) planning, reporting, and communication; (ii) establishment of procedures and systems; (iii) review and preparation of plans, manuals and reports; (iv) overall project management, monitoring and implementation; and (v) social, environmental, archaeological, occupational health and safety, community participation and gender action compliance monitoring.

78. In order to ensure effective implementation of safeguard related components in the project, PMU will have safeguard experts (one environmental specialist and one social development specialist) in the team. These safeguard experts will ensure implementation of environmental management plan of sub-project at site through contractor.

79. The PMC team will also have safeguard specialists in the team. These safeguard specialists will support PMU safeguard specialists during the project implementation, reporting, safeguards related documents preparation, disclosure and capacity building of PMU site team and contractors.

80. The contractor in the current Boundary wall of ASU will appoint one environmental and safety officer for the implementation of IEE and EMP requirements at site. The project implementation arrangement for safeguard compliance has been shown below in **Figure-8**.

81. The EMP for ASU boundary wall construction for pre-construction, construction and operation phases is given in **Tables-11 to 13**.

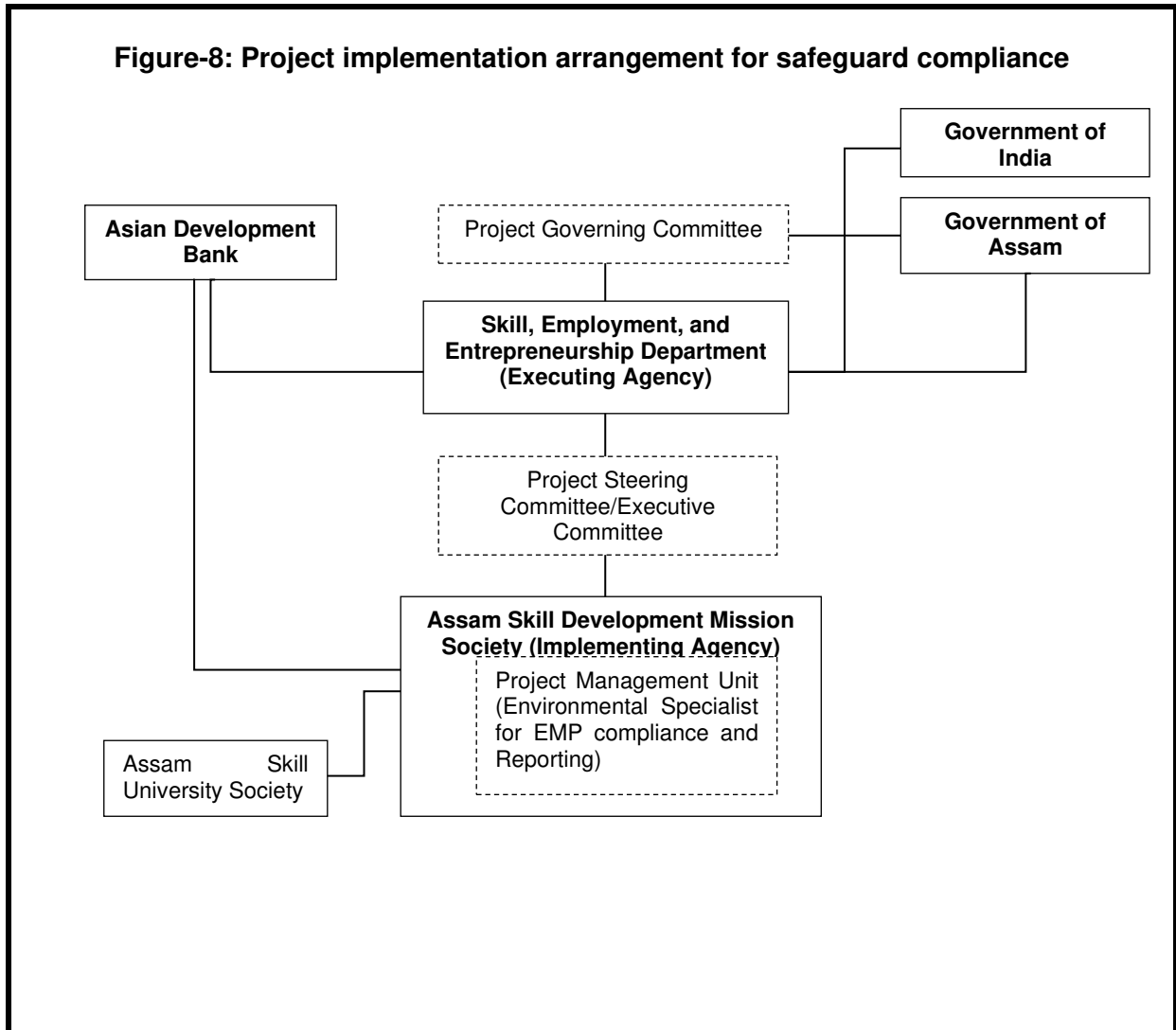

B. Responsibility for updating IEE during Pre-Construction and Construction

82. **Responsibility for monitoring.** During construction, the environmental specialist of the safeguards cell at PMU and environmental specialist of PMC will monitor the contractor's performance and will update IEE if there is change in scope of ASU boundary wall or any new component is added. During the operation phase, monitoring will be the responsibility of the PMU. The environmental specialist PMU will prepare semi-annual reports.

83. **Responsibility for Reporting.** PMU at ASDM will submit semi-annual reports on the implementation of the EMP to ADB. It will permit ADB to field environmental review missions to examine in detail, the environmental aspects of the project. Any major lapses in adhering to the IEE and/or EMPs for specific sub-projects should be reported to ADB immediately. The PMC's environment specialist will assist the PMU in finalizing the semi-annual and annual progress reports. For any non-compliance observed, corrective actions will be implemented in a time bound manner. The cost for mitigating non-compliance will be borne by the contractor as per contract provisions. In case of mitigation costs not coming in scope of contract, these will be met out of contingencies built in the overall project cost.

Table-11: Pre-Construction Phase Environmental Management Plan for Boundary Wall Construction

Sl. No.	Environmental Issues	Mitigation Measures	Parameters (Indicators for Compliance)	Responsible for Implementation	Responsible for Supervision	Frequency for Monitoring	Sources of Fund for Implementing Mitigation Measure
1	Lack of sufficient planning to assure long term sustainability of the improvements and ensure protection of the assets created	Design has included provisions for ensuring effective maintenance and protection of boundary wall so as to ensure the long-term sustainability. The long-term sustainability has been ensured by taking into consideration appropriate Bureau of Indian Standards Codes (BIS) for design, Seismic Zone V coefficient, appropriate wind load factor (corresponding to 39 m/s wind speed), and detailed design after completing topographic survey of ASU site.	Verification of site specific design parameters	Site team of PMU	PMU and PMC	Review after completion of detailed design	Part of project cost
2	Layout of components to avoid impacts on the aesthetics of the project site and surroundings	The boundary wall will not have any adverse impacts on aesthetics of site as there will be only erection of boundary wall. However, boundary wall exterior looks will match the local building exteriors in the project region.	Boundary wall exterior	Site team of PMU	PMU and PMC	Review of exterior color of boundary wall after completion of brickwork and plaster	Project cost
3	Increased storm water runoff from alterations of the site's natural drainage patterns due to	The boundary wall construction will not increase any significant paved surface. But subsequent layout finalization and design of	Arrangement for proper diversion of storm water runoff	PMU site team	PMU	Design of drainage system and layout of ASU	Incidental to construction cost

Assam Skill University Project
Initial Environmental Examination for Boundary Wall Construction

Sl. No.	Environmental Issues	Mitigation Measures	Parameters (Indicators for Compliance)	Responsible for Implementation	Responsible for Supervision	Frequency for Monitoring	Sources of Fund for Implementing Mitigation Measure
	landscaping, excavation works, construction of parking lot, and addition of paved surfaces	ASU will take care of site storm water runoff quick disposal.					
4	Consents, permits, clearances, no objection certificate (NOC), etc.	Obtain all necessary consents, permits, clearances, NOCs, etc. prior to start of civil works. Acknowledge in writing and provide report on compliance, all obtained consents, permits, clearances, NOCs, etc.	Consents, permits, clearance and NOCs Records and communications	PMU site Team	PMU	Check permission from district administration	Project cost
5	Establishment of baseline environmental conditions prior to start of civil works	1. Conduct documentation of location of components, areas for construction zone (camp, staging, storage, stockpiling, etc.) and surroundings (within direct impact zones). Include photos and GPS coordinates. 2. Carry out environmental monitoring at project site for ambient air quality, water quality and noise levels to establish baseline environmental monitoring for the parameters indicated in the monitoring plan.	Records and photographs, baseline environmental monitoring results	Contractor	PMU site team	Once prior to start of construction works	Contractor

Assam Skill University Project
Initial Environmental Examination for Boundary Wall Construction

Sl. No.	Environmental Issues	Mitigation Measures	Parameters (Indicators for Compliance)	Responsible for Implementation	Responsible for Supervision	Frequency for Monitoring	Sources of Fund for Implementing Mitigation Measure
6	Utilities	<ul style="list-style-type: none"> The locations and operators of utilities to be impacted for the boundary wall construction should be identified and documented in detailed design documents to prevent unnecessary disruption of services during the construction phase. Require contractor to prepare a contingency plan to include actions to be done in case of unintentional interruption of services. Obtain from the site team of PMU the list of affected utilities and operators. If relocations are necessary; contractor will coordinate with the providers to relocate the utility. 	<p>List and maps showing utilities to be shifted</p> <p>Contingency plan for services disruption</p>	<ul style="list-style-type: none"> PMU site team will prepare preliminary list and maps of utilities to be shifted During detailed design phase, contractor to prepare (i) list and operators of utilities to be shifted; and (ii) contingency plan 	PMU site team	After delineation of boundary wall at site	Contractor
7	Social and cultural resources	Develop a protocol for use by the contractors in conducting any excavation work, to ensure that any chance finds are recognized and measures are taken to ensure they are protected and conserved.	Chance find protocol	PMU safeguard specialist to develop protocol for chance finds	PMU	Prior to start of construction activities	Project cost
8	Construction camp-	Sitting of the construction	Construction	Contractor	PMU	At the time of	Contractor

**Assam Skill University Project
Initial Environmental Examination for Boundary Wall Construction**

Sl. No.	Environmental Issues	Mitigation Measures	Parameters (Indicators for Compliance)	Responsible for Implementation	Responsible for Supervision	Frequency for Monitoring	Sources of Fund for Implementing Mitigation Measure
	locations, selection, design and layout	<p>camp, if required, at project site shall be as per the guidelines below and details of layout to be approved by PMU.</p> <p>The potential sites for labor camp and construction camp shall be identified by the contractor and this identified site shall be visited by the environmental specialist of PMU and one having least impacts on environment will be approved by the PMU. As far as possible, construction camp and labor camp will be established within the boundary of plot for the project to avoid impacts on private land. Locations for storage of construction materials shall be identified at the site or at existing buildings in the Mangaldoi town. Sanitation facilities at construction camps shall be adequately planned.</p>	Camp sites, and locations of material storage areas, sanitation facilities			construction camp establishment and finalization of storage areas	
9	Sources of construction materials	Use quarry sites and sources compliant with environmental regulations of India at the national, state and local levels.	Environmental permissions issued to quarries and sources of materials	Contractor PMC and PMU site Team to verify sources (including permits)	PMU team site and PMC	Upon submission by contractor	Project cost

Assam Skill University Project
Initial Environmental Examination for Boundary Wall Construction

Sl. No.	Environmental Issues	Mitigation Measures	Parameters (Indicators for Compliance)	Responsible for Implementation	Responsible for Supervision	Frequency for Monitoring	Sources of Fund for Implementing Mitigation Measure
		<p>Verify suitability of all material sources and obtain approvals from PMU.</p> <p>Submit to PMU on a monthly basis documentation of sources of materials.</p>		if additional is requested by contractor			
10	Access for construction material transportation	<p>Plan transportation routes so that heavy vehicles do not use narrow local roads, except in the immediate vicinity of ASU project site.</p> <p>Schedule transport and hauling activities during non-peak hours.</p> <p>Locate entry and exit points in areas where there is low potential for traffic congestion.</p> <p>Keep the site free from all unnecessary obstructions.</p> <p>Drive vehicles in a considerate manner.</p> <p>Coordinate with the Traffic Police Department for temporary road diversions and for provision of traffic aids if transportation activities cannot be avoided during</p>	Traffic management plan	Contractor	PMU and PMC	During delivery of construction materials	Contractor

Sl. No.	Environmental Issues	Mitigation Measures	Parameters (Indicators for Compliance)	Responsible for Implementation	Responsible for Supervision	Frequency for Monitoring	Sources of Fund for Implementing Mitigation Measure
		peak hours.					
11	Occupational health and safety	<p>Comply with IFC EHS Guidelines on Occupational Health and Safety.</p> <p>Develop comprehensive site-specific health and safety (H&S) plans. The overall objective is to provide guidance to contractor on establishing a management strategy and applying practices that are intended to eliminate, or reduce, fatalities, injuries and illnesses for workers performing activities and tasks associated with the project.</p> <p>Include in H&S plan measures such as: (i) type of hazards at construction site; (ii) corresponding personal protective equipment for each identified hazard; (iii) H&S training for all site personnel; (iv) procedures to be followed for all site activities; and (v) documentation of work-related accidents.</p>	Health and safety (H&S) plan	Contractor	PMU and PMC	During pre-construction phase	Contractor

Sl. No.	Environmental Issues	Mitigation Measures	Parameters (Indicators for Compliance)	Responsible for Implementation	Responsible for Supervision	Frequency for Monitoring	Sources of Fund for Implementing Mitigation Measure
		(v) Take necessary measures for the protection of COVID-19. Provide medical insurance coverage for workers.					
12	Stakeholder consultations	Continue information dissemination, stakeholder consultations, and involvement/participation of stakeholders during project implementation.	Disclosure records Consultations	PMU,PMC site team, and contractor	PMU	<ul style="list-style-type: none"> • During updating of IEE Report • During preparation of site- and activity-specific plans as per EMP • Prior to start of construction • During construction 	PMU and contractor

Table-12: Construction Phase Environmental Management Plan for Boundary Wall Construction

Sl. No.	Environmental Issues	Mitigation Measures	Parameter (Indicators for Compliance)	Responsible Implementation	Responsible Supervision	Frequency for Monitoring	Sources of Fund for Implementing Mitigation Measure
1	Sanitation and drinking water facilities at construction Camp	The contractor shall provide sanitation facilities at the camp site. These facilities will include dust bins in adequate numbers for solid waste	Construction camp sanitation and drinking water facilities	Contractor	PMU site team	Regularly during construction phase	Contractor

Sl. No.	Environmental Issues	Mitigation Measures	Parameter (Indicators for Compliance)	Responsible Implementation	Responsible Supervision	Frequency for Monitoring	Sources of Fund for Implementing Mitigation Measure
		collection, drinking water facilities, and separate toilets for male and females. These toilets facilities shall be well maintained and septic tanks/soak pits shall be provided at the toilets. The dust bins shall be regularly emptied and waste from camp site shall be disposed off at designated locations.					
2	Traffic circulation plan during construction phase	Prior to commencement of site activities and mobilization on ground, the contractor will prepare and get approved (from the PMU site team and local traffic police) traffic circulation plan during construction for safe passage of public vehicles so that locals are not at inconvenience. The contractor with support of the PMU site team will carry out dissemination of these information and circulation plan at boundary wall construction site	Safe movement of Traffic	Contractor	PMU site team	Every day during construction phase	Contractor
3	Clearance activities, including delineation of construction area	Only ground cover shrubs, if any, that impinge directly on the permanent works or necessary temporary works shall be removed with prior approval from the	Pre-construction records of site and vegetation in area of construction	Contractor	PMU site team	During site clearance activities	PMU

Sl. No.	Environmental Issues	Mitigation Measures	Parameter (Indicators for Compliance)	Responsible Implementation	Responsible Supervision	Frequency for Monitoring	Sources of Fund for Implementing Mitigation Measure
		<p>Environmental Experts of PMU.</p> <p>All areas used for temporary construction operations will be subjected to complete restoration to their former conditions with appropriate rehabilitation procedures. The photographic records shall be maintained for the temporary sites used for construction. These will help in proper restoration.</p>					
4	Drinking water availability at Construction camp and construction site	Sufficient supply of cold potable water to be provided and maintained. If the drinking water is obtained from an intermittent public water supply then storage tanks will be provided. For this, contractor will submit plans which detail how availability of drinking water shall be assured. In case it is obtained from the natural spring then permission from local authorities shall be obtained.	Water supply source and availability of water, permission of local authority if obtained from local spring	Contractor	PMU site team	During construction phase regularly	Contractor
5	Waste disposal	The pre-identified disposal location shall be part of comprehensive waste disposal plan. Solid waste management plan to be	Waste disposal sites, waste management plan	Contractor	PMU site team	Regularly during construction phase	Contractor

Sl. No.	Environmental Issues	Mitigation Measures	Parameter (Indicators for Compliance)	Responsible Implementation	Responsible Supervision	Frequency for Monitoring	Sources of Fund for Implementing Mitigation Measure
		<p>prepared by the contractor in consultation with local civic authorities.</p> <p>The environmental specialist of PMU shall approve these disposal sites after conducting a joint inspection on the site with the contractor.</p> <p>Contractor shall ensure that waste shall not be disposed off near water stream in the surroundings of site and along the access path.</p>					
6	Stockpiling of construction materials	Stockpiling of construction materials will be done in such a way that it does not impact and obstructs the drainage and movements of locals for accessing their agriculture fields. The stockpiles will be covered to protect from dust and erosion.	Stockpiling sites at boundary wall construction site	Contractor	PMU site team	Regularly during construction phase	Contractor
7	Arrangement for construction water	<p>(i) The Contractor shall provide a list of locations and type of sources from where water for construction shall be acquired.</p> <p>(iii) To avoid disruption/disturbance to other water users, the contractor shall</p>	Water availability at identified water source locations	Contractor	PMU site team	Regularly during construction phase	Contractor

**Assam Skill University Project
Initial Environmental Examination for Boundary Wall Construction**

Sl. No.	Environmental Issues	Mitigation Measures	Parameter (Indicators for Compliance)	Responsible Implementation	Responsible Supervision	Frequency for Monitoring	Sources of Fund for Implementing Mitigation Measure
		arrange water from market or from local municipality and consult PMU before finalizing the source.					
8	Water pollution from construction wastes	The contractor shall take all precautionary measures to prevent entering of wastewater and construction waste into local stream during construction.	Sub-project site	Contractor	PMU site team	Regularly during construction phase	Contractor
9	Water pollution from fuel and lubricants	<p>1. The contractor shall not store fuel and lubricants at site to avoid water pollution on account of spillage. These will be purchased on need basis.</p> <p>2. The maintenance of vehicle and equipment shall be avoided at site.</p> <p>3. The contractor shall ensure that all vehicle/machinery and equipment operation, and refueling shall be carried out in such a manner that spillage of fuels and lubricants does not contaminate the ground.</p> <p>4. The monitoring of ground water quality will be taken up as per monitoring plan.</p>	Vehicle parking, refueling sites, etc.	Contractor	PMU site team	Regularly during construction phase	Contractor
10	Soil pollution due to	Fuel and lubricants storage at	Vehicle parking	Contractor	PMU site team	Regularly during	Contractor

**Assam Skill University Project
Initial Environmental Examination for Boundary Wall Construction**

Sl. No.	Environmental Issues	Mitigation Measures	Parameter (Indicators for Compliance)	Responsible Implementation	Responsible Supervision	Frequency for Monitoring	Sources of Fund for Implementing Mitigation Measure
	fuel and lubricants, construction wastes	<p>site will be avoided to avoid soil pollution on account of spillage. These will be purchased on need basis from market.</p> <p>Vehicle and equipment cleaning and washing shall be avoided at site.</p>	area			construction phase	
11	Generation of dust	<p>The contractor will take every precaution to reduce the levels of dust at construction site.</p> <p>All filling works to be protected/covered in a manner to minimize dust generation.</p>	ASU site, air quality monitoring results	Contractor	PMU site team	Regularly during construction phase	Contractor
12	Emission from construction vehicles, equipment and machinery	<p>All vehicles, equipment and machinery used for construction shall conform to the relevant Bureau of India Standard (BIS) norms. The discharge standards promulgated under the Environment Protection Act, 1986 shall be strictly adhered to. The silent/quiet equipment available in the market shall be used in the boundary wall construction.</p> <p>The contractor shall maintain a record of PUC for all</p>	PUC certificates of vehicles and machinery	Contractor	PMU site team	Regularly during construction phase	Contractor

Sl. No.	Environmental Issues	Mitigation Measures	Parameter (Indicators for Compliance)	Responsible Implementation	Responsible Supervision	Frequency for Monitoring	Sources of Fund for Implementing Mitigation Measure
		vehicles and machinery used during the contract period which shall be produced for verification whenever required.					
13	Noise pollution	<p>The contractor shall confirm that all construction equipment used in construction shall strictly conform to the MoEFCC and CPCB noise standards and all vehicles and equipment used in construction shall be fitted with exhaust silencers.</p> <p>At the construction sites noisy construction work such as operation of DG sets, use of high noise generation equipment shall be stopped during the nighttime between 10.00 pm to 6.00 am.</p> <p>Noise limits for construction equipment used in this project will follow IFS's EHS standards.</p>	Certificates of vehicles conforming noise standards, noise monitoring results	Contractor	PMU site team	Regularly during construction phase	Contractor
14	Impacts on flora and fauna	Minimize impacts on flora and fauna during construction phase by limiting site clearance bare minimum and limiting all types of pollution generation.	Environmental monitoring reports	Contractor	PMU site team	Regularly during construction phase	Contractor

**Assam Skill University Project
Initial Environmental Examination for Boundary Wall Construction**

Sl. No.	Environmental Issues	Mitigation Measures	Parameter (Indicators for Compliance)	Responsible Implementation	Responsible Supervision	Frequency for Monitoring	Sources of Fund for Implementing Mitigation Measure
15	Material Handling at construction site	Workers employed on mixing cement, lime mortars, concrete, etc., will be provided with protective footwear and protective goggles. Workers, who are engaged in welding works, will be provided with welder's protective eye-shields.	Data on available personal protective equipment	Contractor	PMU site team	Regularly during construction phase	Contractor
16	Disposal of construction waste, and debris	The contractor shall confirm that safe disposal of the construction waste will be ensured in the pre-identified disposal locations. In no case, any construction waste will be disposed off around the project site.	Disposal site	Contractor	PMU site team	Regularly during construction phase	Contractor
17	Onsite emergency plan for minor accidents and mishaps and Disaster Management Plan for Natural Calamities	The onsite emergency plan will be prepared by the contractor in consultation with PMU site team. For natural calamities, disaster management plan prepared by the Darrang district administration under the provisions of Disaster Management Act 2005 will be followed.	Onsite emergency plan document and Disaster Management Plan document of Darrang District	Contractor	PMU site team	Mock drill every quarter	Contractor
18	Safety measures during construction	Adequate safety measures for workers during handling of	Records of availability of	Contractor	PMU site team	Regularly during construction	Contractor

Sl. No.	Environmental Issues	Mitigation Measures	Parameter (Indicators for Compliance)	Responsible Implementation	Responsible Supervision	Frequency for Monitoring	Sources of Fund for Implementing Mitigation Measure
		<p>materials at the boundary wall construction site will be taken up.</p> <p>The contractor has to comply with all regulations for the safety of workers. Precaution will be taken to prevent danger of the workers from accidental injuries, fire, etc.</p> <p>First aid treatment will be made available for all injuries likely to be sustained during the course of work.</p> <p>The contractor will comply with all anti-malaria instructions given by the PMU site team.</p> <p>Necessary COVID-19 protection measures will be taken up as per requirements of GoA and GoI guidelines.</p>	personal protective equipment, availability of first aid kits			phase	
19	Clearing of construction of camp and restoration	<p>The contractor to prepare site restoration plan for approval by the PMU site team. The plan is to be implemented by the contractor prior to demobilization.</p> <p>On completion of the works, all temporary structures will</p>	Restoration plan, and records of pre-construction of temporary sites	Contractor	PMU site team	End of construction phase	Contractor

Sl. No.	Environmental Issues	Mitigation Measures	Parameter (Indicators for Compliance)	Responsible Implementation	Responsible Supervision	Frequency for Monitoring	Sources of Fund for Implementing Mitigation Measure
		be cleared away, all rubbish burnt, excreta or other disposal pits or trenches filled in and effectively sealed off and the site left clean and tidy, at the contractor's expense, to the entire satisfaction of the ASDM.					

Table-13: Operation Phase Environmental Management Plan for Boundary Wall Construction

Sl. No.	Environmental Issues	Mitigation Measures	Parameter (Indicators for Compliance)	Responsible Implementation	Responsible Supervision	Frequency for Monitoring	Sources of Fund for Implementing Mitigation Measure
1	Unhygienic conditions due to poor maintenance of sanitation facilities and irregular solid waste collection at the entrance gate	The ASU through its operation and management team and/or staff will carry out maintenance of the toilets at the entrance gate and carry out the regular collection and disposal of wastes to a designated waste treatment site. For solid waste disposal suitable site will be identified or waste will be disposed off at location where Mangaldoi town waste is being disposed off. Septic tanks will be maintained and regularly emptied.	Maintenance schedule of the entrance gate office and facilities created	ASU operations and management team	PMU ASDM	Every quarter	ASU's operational budgets

**Assam Skill University Project
Initial Environmental Examination for Boundary Wall Construction**

Sl. No.	Environmental Issues	Mitigation Measures	Parameter (Indicators for Compliance)	Responsible Implementation	Responsible Supervision	Frequency for Monitoring	Sources of Fund for Implementing Mitigation Measure
2	Safety risks	The boundary wall will be well maintained and manned for the security of ASU.	Maintenance schedule of boundary wall, entrance gate, etc.	ASU operations and management team	PMU ASDM	Regularly	ASU operational budgets
3	Natural disasters	Necessary procedures to be followed by the visitors, students, ASU Staff during natural disasters shall be written at prominent locations.	Warnings of disasters by Meteorological Department	ASU operations and management team	District Administration	During disasters	Government of Assam
4	Onsite emergency plan for minor accidents and mishaps and	The operations and management team of ASU will prepare on site emergency plan for possible minor accidents and mishaps during operation phase.	Onsite emergency plan document	Head ASU operations and management	PMU ASDM	Mock drills every quarter	ASU operational budgets

C. Environmental Monitoring Plan

84. Environmental monitoring will be undertaken during construction at three levels. Environmental monitoring (covers EMP implementation and compliance with rules and regulations with respect to the environment, and handling of solid and liquid waste) at site will be undertaken by the contractor during pre-construction and construction phases, and will be supervised by PMU (through PMC and PMU site team). Environmental monitoring during operation phase for this boundary wall construction of ASU has not been recommended as there are no environmental impacts during operation phase except minor repair works. Water logging is not anticipated as ASU layout design will take care of ASU campus drainage. The environment and social safeguards specialists of the PMU and PMC will ensure that IEE and EMP are updated for any changes in design in accordance with ADB's and GoA's requirements. The PMU site team and environmental specialist will ensure that all the provisions of the EMP are being adhered to by the contractor.

85. To ensure the effective implementation of mitigation measures and EMP during pre-construction and construction phases of this sub-project, it is essential that an effective environmental monitoring plan is followed as given in **Table 14**. The proposed monitoring of all relevant environmental parameters, with a description of the sampling stations, frequency of monitoring, applicable standards and responsible agencies are presented in this table.

Table-14: Environmental Monitoring Plan for Boundary Wall Construction for Preconstruction and Construction Phases

Sl. No.	Field (Environmental Attribute)	Phase	Parameters to be Monitored	Locations	Frequency	Responsibility	Cost (INR/US\$)
1	Air Quality	During pre-construction phase	CO, NO _x , PM ₁₀ , PM _{2.5} , and SO ₂	Boundary wall construction site	Once in the pre-construction phase to establish baseline	Contractor and PMU site team through approved Monitoring Agency	INR20,000/US \$280
		During construction phase			Once in construction phase		
2	Water quality	During pre-construction phase	TDS, TSS, pH, Hardness, BOD, Faecal Coli form	Ground water close to ASU construction site	Once in pre-construction phase to establish baseline	Contractor and PMU site team through approved monitoring agency	INR20,000/US \$280
		During construction phase			Once in construction phase		
3	Noise Levels	During pre-construction phase	Noise quality as per National Ambient Noise Standards on dB(A) scale	Noise levels at boundary wall construction site	Once in pre-construction phase to establish baseline	Contractor and PMU site team through approved monitoring agency	INR 20,000/US \$280
		During construction phase			Once in construction phase		
		Operation phase					

Note: Monitoring in operation phase has not been recommended as there will be no environmental impacts from the boundary wall after construction.

Summary of Site- and Activity-Specific as per ASU EMP

86. **Table-15** summarizes site- and activity-specific plans to be prepared as per EMP tables.

Table-15: Site- and Activity-Specific Plans/Programs as EMP

To be Prepared During	Specific Plan/Program	Purpose	Responsible for Preparation	Responsible for Implementation
Pre-construction phase	Environmental monitoring program as per detailed design	Indicate sampling locations, methodology and parameters to the contractor	PMU and PMC	Contractor
Pre-construction phase	Chance find protocol	Address archaeological or historical chance finds	PMU environmental specialist	Contractor
Pre-construction phase	List of pre-approved sites for construction camp, stockpiles, and waste disposal sites	Location/s for construction camp for boundary wall construction force, areas for stockpile, storage and disposal for minimization of impacts	PMU environmental specialist, PMU site team and contractor	Contractor
Pre-construction phase	Waste/spoil management plan	Mitigate impacts due to waste generation	Contractor	Contractor
Pre-construction phase	Spill prevention and containment plan	Mitigate impacts of accidental spills of oil, lubricants, fuels, concrete, and other hazardous materials	Contractor	Contractor
Construction phase	Traffic management plan	Mitigate impacts due to transport of materials and project related traffic movement	Contractor	Contractor
Construction phase	Health and safety (H&S) plan	To comply with IFC EHS Guidelines on Occupational health and safety To comply with COVID-19 guidelines issued by the GoA and Ministry of Health Gol	Contractor	Contractor
Construction phase	Erosion control and re-vegetation plan	Mitigate impacts due to erosion and vegetation removal at ASU site	Contractor	Contractor
Construction phase	Environmental monitoring plan implementation	To check efficacy of mitigation measures	Environmental Specialist of PMU and contractor	Contractor

87. The guidelines for preparation of site-specific traffic management plans have been provided in **Annexure-4**.

D. Capacity Building

88. In addition to the primary objective of project strengthening industry-aligned and flexible skills education and training systems in Assam, the sub-project will also raise awareness about environmental conservation amongst trainees, implementing agency, and local communities. The project will have the opportunity to build capacity in environment protection for the above mentioned stakeholders.

89. The environmental specialists at PMU and PMC will provide the basic training required for environmental awareness. Specific modules customized for the available skill set will be devised after assessing the capabilities of the members of the training program and the requirements of the project. In this boundary wall sub-project, the environmental specialist of PMU will carry out capacity building training program for PMU site team and contractor workforce by organizing periodic training programs. The training programs will be oriented on regulatory compliances, ADB SPS 2009, EMP implementation and reporting.

E. Environmental Budget

90. Most of the mitigation measures require the contractor to adopt good site practices, which should be part of their normal procedures already, hence there are unlikely to be major costs associated with compliance. Only those items not covered under budgets for construction are included in the IEE budget. The IEE costs include mitigation, monitoring and capacity building costs. The summary budget for the environmental management costs for the sub-project is presented in **Table 16**.

Table-16: Environmental Management and Monitoring costs (INR)

Monitoring Component	Rate	Amount (INR)	Source of Fund
Pre-Construction and Construction Phase			
Air Quality: One location at boundary wall construction site (one sample during pre-construction phase) and one sample during construction phase (Total 2 samples)	10,000	20,000	Contractor
Water Quality: One ground water sample from boundary wall construction site, (one sample during pre-construction) and one sample during construction phase (Total 2 samples)	10,000	20,000	Contractor
Noise Quality: One location at boundary wall construction site (one sample during pre-construction phase) and one sample during construction phase (Total 2 samples)	3000	6,000	Contractor
Total: Pre-Construction and Construction Phase Monitoring Cost (A)		46,000	
O&M Phase: No monitoring planned as no environmental impacts anticipated from boundary wall after completion of construction.			
Total O&M Phase Monitoring Cost (B)		0	
Total Cost (A+B)		46,000	
Contingencies @ 5 %		23,00	
Total Budgeted Cost (INR)		48,300 (approx. 50,000)	

F. Environmental Monitoring and Reporting

91. The PMU with the assistance of PMC will monitor and measure the progress of EMP implementation during construction phase. During operation phase PMU safeguard cell will take care of EMP implementation. PMU site team will submit monthly monitoring and implementation reports to ASDM. The PMU environmental specialist at ASDM prepares semi-annual monitoring reports for submission to ADB on behalf of EA. Monitoring reports will be posted in a location accessible to the public.

92. ADB will review project performance against the EA's commitments as agreed in the legal documents. The extent of ADB's monitoring and supervision activities will be commensurate with the project's risks and impacts. Monitoring and supervising of social and environmental safeguards will be integrated into the project performance management system. ADB will monitor projects on an ongoing basis until a project completion report is issued.

VII. PUBLIC CONSULTATION AND INFORMATION DISCLOSURE

A. Process For Consultations Followed

93. The construction and maintenance of the boundary wall of ASU does not involve any elements which could have an adverse impact on the community. There is no deprivation of any sort for the residents or displacement of any groups. Particularly, with regard to environmental impacts, this ASU boundary wall component can be characterized as innocuous.

94. In view of this, the need for holding a public hearing (as defined in EIA Notification 2006 of GoI) is not perceived at this stage. However, in compliance with the ADB's guidelines, focused public consultations were undertaken during the site visit to Mangaldoi ASU site. The consultations were also held with the Deputy Commissioner Mangaldoi, Revenue Authorities of district and locals living close to the project site. The stakeholders were informed about the project, construction of boundary wall and subsequent functioning in their area and their views were obtained. During the preparation of this IEE, consultations have been held with the ASDM and State Department of Forest and Environment. These consultations were carried out on November 12 and 13, 2020. The number of participants (male and female) has been given in

95. The process of consultations was taken up, as an integral part of the sub-project design and environmental assessment, in accordance with ADB's guidelines and following objectives:

- To educate the general public, specially potentially impacted or benefited communities, individuals and stakeholders about the proposed ASU and construction of boundary wall of site as one of the first component of the ASU;
- To familiarize the people with technical and environmental issues of the boundary wall construction and major components of ASU project for better understanding;
- To solicit the opinion of the communities, local authorities and individuals on environmental issues and assess the significance of impacts due to the proposed development;
- To foster co-operation among officers of EA and IA, the community and the stakeholders to achieve a cordial working relationship for smooth implementation of the sub- project; and
- To identify the environmental issues relating to the proposed activity.

96. During the consultations local residents opined that there is need to provide skills and job-oriented education to the youth of Assam State so that better placement opportunities are made available to them. The ASU project will help skilled rural youth in getting training and skills enhancement education. The project will also provide employment and business opportunities to locals during the construction and operation phases. The locals demanded fast implementation of the boundary wall sub-project as well as overall project. The dates of consultations and stakeholders consulted have been summarized below in **Table 17**. The views, comments and suggestions of stakeholders and their incorporation in project design are presented in **Tables 18 and 19**. The records of consultations (list of participants with signatures) and consultation photographs are given in **Annexure- 5**.

Table-17: Dates and Stakeholders Consulted

Sl. No.	Stakeholders Consulted	Dates of Consultations	Number of Participants	
			Male	Female
1	Project Site	12 and 13 November 2020	10	4
2	Deputy Commissioner Darrang Office	12 November 2020	12	4
3	Assam Skill Development Mission	12 and 13 November 2020	9	2
4	District Revenue Authorities	13 November 2020	4	0

97. It is clear from **Tables 18 and 19** that most of the suggestions of stakeholders have been taken care in the project design.

Table-18: Views, Comments, and Suggestions of Stakeholders at Project Site and Considerations in Sub-Project Design

Sl. No.	Place	Date	Consultations held with	Issues discussed	Outcome of discussions and consideration in project design and Implementation
1	Project Site	12/11/2020 and 13/11/2020	With locals near the site, ASDM officials and State Assembly elected representatives	Project components, Boundary of project site components, benefits of project, implementation schedule, environmental and social impacts during project implementation, etc.	<ol style="list-style-type: none"> 1. Participants, especially elected State Assembly Member (MLA), welcomed the commencement of project and assured all help during project implementation. The environmental specialist of PPTA Team and ASDM officials thanked the MLA. 2. One local participant suggested that locals should be given preference in supply of construction materials and employment during the construction. The environmental specialist replied that contractors once appointed will procure man power and materials. At that time locals may interact with them for supply of materials and employment. 3. One participant enquired about access road to the ASU site. The environmental specialist replied that access road from NH-15 will be developed. Once Mangaldoi Bypass is implemented by the National Highways Authority of India, then access road from new bypass will also be developed. 4. The environmental specialist solicited suggestions for environment protection from the participants. The participants suggested that plantation should be done and waste disposal should be taken care. The environmental specialist replied that plantation and landscaping plan for the campus will be prepared and implemented. The solid waste disposal will be as per regulatory requirements. 5. One local participant suggested during discussion that there is intense rainfall in Mangaldoi so drainage should be taken care. The consultant and ASDM officials informed that campus will be designed with proper drainage system considering rainfall.

Table-19: Summary of Stake Holder Consultations at Institutional Level

Sl. No.	Place and date	Consultations held with	Issues discussed	Outcome of discussions and consideration in project design and Implementation
1.	Deputy Commissioner Darrang Office 12/11/2020	Darrang District Deputy Commissioner, Local NGO, Revenue Officials, Darrang Municipal Council Elected Representatives	Project components, boundary of project site components, benefits of project, implementation schedule, environmental and social impacts during project implementation, etc.	<ol style="list-style-type: none"> 1. The Darrang District Deputy Commissioner informed ADB project preparation consultant team that elected public representatives are in favor of project and district administration will extend all help for the project. He further suggested that Darrang district being agriculture predominant area so modern courses based on agro processing, and local agriculture based products should be taught in the ASU. ASDM team replied that suggestion has been noted and while finalizing the courses the suggestion will be considered. 2. One participant suggested that if trees are to be cut then these should be replanted at another location. The environmental specialist replied that there is no requirement of tree cutting as site is flat and vacant. 3. The official from local office of State Pollution Control Board suggested that environmental impacts of the project should be assessed thoroughly. The environmental specialist replied that environmental assessment of the project is being done and an IEE report will be completed as part of project preparation. 4. One participant suggested that small portion of ASU should also develop a water body. In this water body rainwater should be collected from roof top as well as from ground. This will help in ground water recharge. ADB project preparation consultant team replied that suggestion has been noted and will be considered while finalizing layout plan of ASU. 5. The Deputy Commissioner informed that after COVID-19 pandemic cultivation on land is in demand by the youth. Darrang district is a major production center of maize so courses related to food processing should be offered at ASU. The ASDM officials replied that suggestion has been noted and courses pertaining to food processing will be planned. 6. One participating NGO from Darrang suggested that jute production is good in Darrang district and jute is exported so local youth should be trained for export of jute based products and exotic vegetables. The ASDM officials replied that suggestion has been noted and courses will be planned considering the

**Assam Skill University Project
Initial Environmental Examination for Boundary Wall Construction**

Sl. No.	Place and date	Consultations held with	Issues discussed	Outcome of discussions and consideration in project design and Implementation
				suggestions given in the consultation meeting.
2.	Guwahati 12/11/2020 and 13/11/2020	ASDM Director and Officials	Site Issues, project component finalization and project site revenue records	<p>1. Environmental specialist enquired about land title and tree cutting requirements at site. The ASDM Director informed that there is no requirement for tree cutting. The land in the name of ASDM has been transferred.</p> <p>2. The environmental specialist informed that project will be category B as per ADB safeguard policy Statement 2009 (SPS 2009). To comply with the policy an IEE report containing in Environmental Management Plan (EMP) will be prepared for each component. The EMP is to be included in bid document and EMP budget in project cost. The ASDM officials replied that compliance with ADB SPS 2009 and regulatory requirements will be ensured.</p>

B. Future Consultation and Information Disclosure

98. To ensure continued public and stakeholder participation in the sub-project life cycle, periodic consultations and focus group discussion should be continued. A grievance redress committee (GRC) will be formed at the site and also at PMU level to register grievances of the people regarding technical, social and environmental issues. The participatory process will ensure that all views of the people are adequately reviewed and suitably incorporated in the design and implementation process. Further, to ensure an effective disclosure of the ASU boundary wall proposal to the stakeholders and the communities in the vicinity of site, an extensive project awareness campaign will be carried out.

Information Disclosure

99. Electronic version of this IEE will be placed in the official websites of the ASDM and ADB (after clearance of this document by the GoA and ADB). On demand, any person seeking information can obtain a hard copy of the complete IEE document by paying cost of photocopy from the office of the PMU and site office on a written request.

100. The PMU will issue notification on the disclosure mechanism on its website ahead of the initiation of boundary wall construction for the ASU site, providing information on the sub-project, as well as the start dates, etc. This will create awareness of the project implementation among the public.

C. Grievance Redress Mechanism

101. The affected person(s)/aggrieved party can give their grievance verbally or in written to the local site office of sub-project in Darrang. Grievances of affected person will first be brought to the attention of the site in charge, who can resolve the issue at the site level. If the matter is not solved within 7 days period by the site in charge, it will be brought to the GRC constituted for the purpose at site. This GRC shall discuss the issue in its monthly meeting and resolve the issues within one month of time after receiving the grievance. If the matter is not resolved by GRC at site level within stipulated time, it shall be referred to GRC at PMU level by Project Manager of PMU site Team.

102. GRC at PMU shall discuss the issue and try to resolve it and inform the PMU site team accordingly. If the matter is not resolved by the GRC at PMU level within one month of time the matter will be referred to the state level project steering committee (SPC), who will resolve the complaint within one month. However, the aggrieved person/party can bring the matter to the Court of Law any time. The PMU and site office shall keep records of all grievances received including contact details of complainant, date of receiving the complaint, nature of grievance, agreed corrective actions and the date these were affected and final outcome. For this a complaint register will be maintained at Boundary wall construction site. The grievance redress process is shown below. The cost for functioning of GRM will be accounted for in project cost as part of PMU functioning.

103. Further, person(s)/aggrieved party who are, or may be, adversely affected by the ASU project may submit complaints to ADB's Accountability Mechanism. The accountability mechanism provides an independent forum and process whereby people can voice, and seek a resolution of their problems, as well as report alleged violations of ADB's operational policies and procedures. Before submitting a complaint to the Accountability Mechanism, affected person(s)/aggrieved party should first make a good faith effort to solve their problems by working with the ADB South Asia operations department including the India Resident Mission.

D. Composition and functions of GRC

104. **Site Level Grievance Redress Committee (GRC-Site).** This committee will comprise of Project Manager PMU one local elected representative from Panchayat and Contractor site incharge. The GRC-Site will be headed by Project Manager PMU. It will meet at least once a month. The agenda of the meeting will be circulated to all the members and the affected persons/aggrieved party along with venue, date and time at least a week prior to the meeting. The matters shall remain with GRC at site level for one month.

105. **GRC at PMU.** There shall be one GRC in PMU. GRC at PMU will include the Director ASDM, safeguard specialists (Environmental and Social) of the PMU and Finance Officer/Manager of PMU/ASDM. The Committee shall be headed by the Mission Director, ASDM. This committee shall look into the matters, which are referred to and not resolved by GRC at site level. If the matter is not resolved by the GRC at PMU level within one month of time, then the aggrieved person or party can bring the matter to the state level project steering committee (PSC) which is in-charge of the overall ASU Project.

106. **Approach to GRC.** Affected person or aggrieved party can approach the GRC for redress of his/their grievances through any of the following modes:

- Web based: A separate corner will be developed at the ASDM/ASU website (s) so that public and affected person can register their complaints in the online column.
- Telecom based: A telephone number will be displayed at the web site of ASDM/ASU and at the construction site so that general public can register their complaint through telephone and mobile phone to the site team and PMU office. One complaint register will also be maintained at construction site.
- Construction site. The grievance redress mechanism for the ASU project for safeguards related issues has been shown below in **Figure-9**:

Figure-9: Grievance Redress Mechanism (ASU Project)

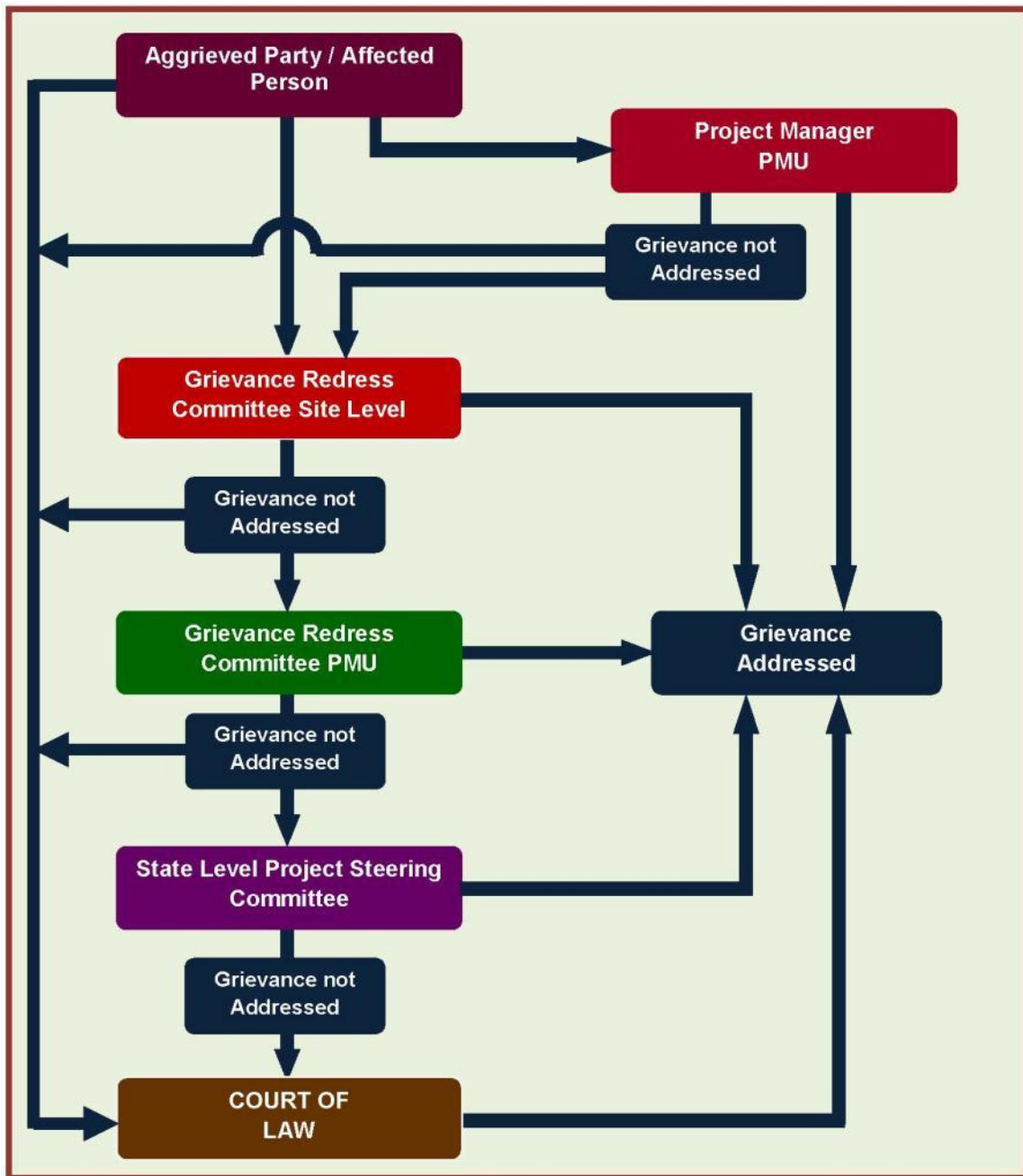

VIII. FINDINGS AND RECOMMENDATIONS

107. The construction of boundary wall for the ASU does not involve any interventions in and around the natural and cultural heritage destinations and have less significant (direct and indirect) environmental impacts. It is expected that the ASU will offer industry-aligned and flexible skills education and training programs for youths and adults. The boundary wall is a part of ASU and will provide security to the campus.

108. This IEE has identified minor likely impacts on water, air and noise during construction and has defined mitigation measures. Minor impacts have also been identified during operation phase and mitigation measures for these have also been given in the IEE. Those mitigation measures will be implemented and monitored during the sub-project execution. The overall environmental quality of ASU project site and surroundings will not be affected as a result of boundary wall construction.

109. The specific management measures laid down in the IEE will effectively address any adverse environmental impacts due to the sub-project. The effective implementation of the measures proposed will be ensured through the building up of capacity towards environmental management within the PMU supplemented by the technical expertise of safeguards specialists of the PMU and PMC. Further, the environmental monitoring plan provides adequate opportunities towards course correction to address any residual impacts during boundary wall construction.

VII. CONCLUSIONS

110. On the basis of the IEE, it is expected that the boundary wall construction for ASU project site has only minor, localized, temporary and reversible environmental impacts. These can be easily mitigated through adequate mitigation measures and regular monitoring during the design, construction and post construction phases of the sub-project. Negative impacts on water, air quality and noise levels during civil works will be appropriately monitored and adequately mitigated. This report has not identified any comprehensive, broad, diverse or irreversible adverse impacts caused by the sub-project. Based on the findings of the IEE, the classification of the sub-project as Category "B" is confirmed. No further special study or detailed EIA needs to be undertaken to comply with ADB SPS (2009).

ANNEXURE-1: MOEFCC NOTIFICATION ON EXEMPTION OF ENVIRONMENTAL CLEARANCE FOR EDUCATIONAL INSTITUTIONS

[भाग II-खण्ड 3(ii)]	भारत का राजपत्र : असाधारण	3		
MINISTRY OF ENVIRONMENT, FORESTS AND CLIMATE CHANGE				
NOTIFICATION				
New Delhi, the 22nd December, 2014				
<p>S.O. 3252(E).—Whereas, a draft notification further to amend the notification number S.O 1555(E), dated the 14th September, 2006 (hereinafter referred to as the principal notification), was published, as required under sub-rule (3) of rule 5 of the Environment (Protection) Rules, 1986 in the Gazette of India, Extraordinary, Part II, Section 3, Sub-section (ii) vide number S.O. 2319, (E) dated the 11th September, 2014 (hereinafter referred to as the said notification), inviting objections and suggestions from all persons likely to be affected thereby within a period of sixty days from the date on which copies of Gazette containing the said notification were made available to the public;</p>				
<p>And whereas, copies of the said notification were made available to the public on 11th September, 2014;</p>				
<p>And whereas, no objections or suggestions have been received in response to the said notification within the specified period of sixty days;</p>				
<p>Now, therefore, in exercise of the powers conferred by Sub-section (1) and clause (v) of Sub-section (2) of Section 3 of the said Environment (Protection) Act, 1986 (29 of 1986) read with clause (d) of sub-rule (3) of rule 5 of the Environment (Protection) Rules, 1986, the Central Government hereby makes the following amendments in the said notification, namely:—</p>				
<p>In the principal notification, in the Schedule, under Column (1), for item 8 relating to Building/Construction Projects/Area Development Projects and Townships and sub-items 8 (a) and 8 (b) and the entries relating thereto, specified there under, the following item, sub-items and entries shall be substituted, namely:—</p>				
(1)	(2)	(3)	(4)	(5)
"8	Building or Construction projects or Area Development projects and Townships			
8 (a)	Building and Construction projects		>20000 sq.mtrs and < 1,50,000 sq. mtrs. of built up area	<p>The term "built up area" for the purpose of this notification the built up or covered area on all floors put together, including its basement and other service areas, which are proposed in the building or construction projects.</p> <p>Note 1.- The projects or activities shall not include industrial shed, school, college, hostel for educational institution, but such buildings shall ensure sustainable environmental management, solid and liquid waste management, rain water harvesting and may use recycled materials such as fly ash bricks.</p> <p>Note 2.- "General Conditions" shall not apply.</p>
8	Townships and Area Development Projects		Covering an area of > 50 ha and or built up area > 1,50,000 sq. mtrs	<p>A project of Township and Area Development Projects covered under this item shall require an Environment Assessment report and be appraised as Category 'B1' Project.</p> <p>Note.- "General Conditions" shall not apply.</p>

[F. No. 19-2/2013-IA-III]
MANOJ KUMAR SINGH, Jt. Secy.

Note: The principal rules were published in the Gazette of India, Extraordinary, Part II, Section 3, Sub-section (ii) *vide* Notification Number S.O. 1533(E), dated the 14th September, 2006 and was subsequently amended as follows:—

1. S.O. 1737 (E), dated the 11th October, 2007;
2. S.O. 3067 (E), dated the 1st December, 2009;
3. S.O. 695 (E), dated the 4th April, 2011;
4. S.O. 2896 (E), dated the 13th December, 2012;
5. S.O. 674(E), dated the 13th March, 2013;
6. S.O. 2559 (E), dated the 22nd August, 2013 ;
7. S. O. 2731 (E), dated the 9th September, 2013;
8. S. O. 562(E), dated the 26th February 2014; and
9. S. O. 1599(E), dated the 25th June, 2014.

F. No. 19-2/2013-IA-III
Government of India
Ministry of Environment, Forest and Climate Change
(Impact Assessment Division)

Indira Paryavaran Bhawan
Aliganj, Jor Bagh Raod
New Delhi-110 003

Dated: 09th June, 2015

OFFICE MEMORANDUM

Sub: Clarification regarding Gazette Notification No. S.O. 3252 (E) dated 22.12.2014 on applicability of Environment Clearance-reg.

Vide Gazette Notification No. S.O. 3252 (E) dated 22.12.2014, the Ministry of Environment, Forest and Climate Change has exempted the School, College and Hostel for educational institution from obtaining prior Environment Clearance under the provisions of the EIA Notification, 2006 subject to Sustainable Environmental Management.

The Ministry is in receipt of representation from various educational institutions regarding issuing clarification on status of universities, and other educational institutions. The matter has been further examined in the Ministry and it is clarified that the Notification No. S.O. 3252 (E) dated 22.12.2014 provides exemption to buildings of educational institutions including universities from obtaining prior Environment Clearance under the provisions of the EIA Notification, 2006 subject to sustainable environmental Management. In case of medical universities/institutes the component of Hospitals will continue to require prior Environment Clearance.

The Guidelines to be followed for building projects to ensure sustainable environmental management in pursuance of Notification No. S.O.3252 (E) of 22nd December 2014 under EIA Notification 2006 are at Annexure-I.

This issues with the approval of the Competent Authority.

Manoj
9.6.15
(Manoj Kumar Singh)
Joint Secretary

Copy to:-

1. All the officers of IA Division
2. The Chairperson/Member Secretaries of all the SEIAAs/SEACs.
3. The Chairman of all the Expert Appraisal Committees
4. The Chairman, CPCB
5. The Chairpersons/Member Secretaries of all SPCBs/UTPCCs.
6. IT Consultant, MoEFCC for uploading into the website.

Copy for information:

1. PS to MOS (Independent Charge).
2. PPS to Secretary (EF&CC).
3. All Divisional Head.
4. Website, MoEF&CC
5. Guard File.

ANNEXURE-I

**GUIDELINES TO BE FOLLOWED FOR BUILDING AND CONSTRUCTION PROJECTS
TO ENSURE SUSTAINABLE ENVIRONMENTAL MANAGEMENT
IN PURSUANCE OF NOTIFICATION No. S.O. 3252 (E) OF 22nd DECEMBER, 2014
UNDER ENVIRONMENT IMPACT ASSESSMENT NOTIFICATION, 2006**

[INDUSTRIAL SHED AND EDUCATIONAL INSTITUTIONS]

The Notification dated 22nd December, 2014 has taken out the industrial shed*, school, college, hostel for educational institution from the requirement of prior Environment Clearance (EC) under EIA Notification, 2006 and stipulated that such buildings shall ensure sustainable environmental management, solid and liquid waste management, rain water harvesting and may use recycled materials such as fly ash bricks. These Guidelines will be applicable to all buildings and constructions which come under the ambit of Notification No. S.O. (E) 3252 of 22nd December 2014. To ensure sustainable environment management these guidelines as suited will be applicable on the projects under Item 8 (a) of EIA Notification in addition to the conditions stipulated in the EC.

Land, Air, Noise, Water, Energy, Biological, Socio-economic, and Solid & other Waste Management are the main environment facets to be considered in relation to pre, during & post building construction, therefore, it is necessary to ascertain the baseline data of these environmental facets.

The project proponent should file the information about description of project as per points described below prior to start of the project. Information pertaining to compliance on other points be filed at six monthly interval to the respective State Pollution Control Board and the Regional Office of the Ministry of Environment, Forests and Climate Change.

The compliance of the following will be ensured by the respective State Pollution Control Board before giving 'Consent-to-Operate' to industries and by the Local Urban Bodies and the Development Authorities while giving the 'Occupancy Certificate' to the buildings and constructions. These Certificates should be submitted by the above authorities to the Regional Office of MoEFCC. Ministry of Environment, Forest and Climate Change can assess/evaluate/monitor the compliance of conditions enumerated in the Guidelines through verification by Regional Offices or deputed organisations / person.

S. No.	Environmental Parameters	Implementation and monitoring parameters to be included in local by-laws.
a.	Pre-requisites	<p>Brief description of the project</p> <p>01. Name of the Project, Survey number, Village, Taluka, District, State to be mentioned with Google Earth Image and GPS Co-ordinates of the plot to be submitted.</p> <p>02. Location & distance from nearby landmark places / services to be mentioned.</p> <p>03. Total Built-up area (FSI and Non- FSI) should be mentioned with detailed calculations certified by local planning and sanctioning authority.</p> <p>04. Form 1, Form 1A and Consolidated statement as per Environment Notification dated September 14, 2006 to be submitted to local planning and sanctioning authority, Regional Office, MoEFCC and SPCB</p>
b.	Environment Impacts on Project Land	<p>05. The building layout, set-back/side margin, podium, basement ventilation etc. is prepared based on local building bye-laws and is approved by local competent authorities. The Project Proponent shall obtain all necessary clearance/ permission from all relevant agencies including Town Planning Authority before commencing the work.</p> <p>06. Provisional fire NOC to be obtained from local CFO (Chief Fire Officer)</p> <p>07. "Consent-to-Establish and Consent-to-Operate" shall be obtained as required from State Pollution Control Board as provided in the Air (Prevention and Control of Pollution) Act, 1981 and Water (Prevention and Control of Pollution) Act, 1974</p> <p>08. The project proponent shall put in place a credible enforcement mechanism for compliance of energy conservation measures with its allottees, as projected, in perpetuity. This would be monitored by the designated Energy Conservation/ efficiency Authority in the State.</p> <p>09. Soil and ground water samples will be tested to ascertain that there is no</p>

		<p>threat to ground water quality by leaching of heavy metals and other toxic contaminants.</p> <p>10. Top fertile soil to be preserved and to be later used in landscape.</p> <p>11. The excavation/demolition debris must be disposed off in designated landfill areas or to be used within site for levelling purpose. Under no circumstance, the debris will be disposed in river bed/lakes etc.</p> <p>12. Undertaking to be given by project proponent that occupancy will be given only after drainage and water connections are in place.</p> <p>13. Dust/smoke prevention measures such as wheel washing, water sprinkler, screening, barricading and debris chute must be installed.</p> <p>14. This should comply with the provisions of eco-sensitive zone regulations, coastal zone regulations, heritage areas (identified in the master plan or issued separately as specific guidelines), water body zones (in such zones, no construction is permitted in the water-spread and buffer belt of 30 m minimum around the FTL [full tank level]), various hazard prone area regulations, and others if the site falls under any such area.</p> <p>15. The site planning should take into account heat island effect, size and density of the built-up areas cause heat island effect, wherein higher air temperatures are created in the dense urban areas as against the low-rise surrounding built-up areas. The solar access in the morphology of clusters can be understood in terms of utilization of direct (and not reflected or diffused) solar radiation, mainly for day lighting and heat gain. This defines the minimal distances between the buildings and the relations between built-up volume and open spaces.</p> <p>16. The proportion of open spaces and built-up edges should be designed such that it ensures winter solar access and summer ventilation.</p>
c.	Water	<p>17. Proponent shall obtain permission for ground water withdrawal from State Ground Water Authority.</p> <p>18. Storm water control and its re-use as per CGWB and BIS standards for various applications.</p> <p>19. The natural flow of existing storm water channel should not be altered or diverted.</p> <p>20. Keeping in view the use of large quantities of water in curing, measures for reducing water demand during construction should be followed. Curing water should be sprayed on concrete structures; free flow of water should not be allowed for curing. After liberal curing on the first day, all concrete structures should be painted with curing chemical to save water. Concrete structures should be covered with thick cloth/gunny bags and then water should be sprayed on them. This would avoid water rebound and will ensure sustained and complete curing. Ponds should be made using cement and sand mortar to avoid water flowing away from the flat surface while curing.</p> <p>21. The developer should ensure groundwater and municipal water meet the water quality norms as prescribed in the Indian Standards for various applications (Indian Standards for drinking [IS 10500-1991], irrigation applications [IS 11624-1986]).</p> <p>22. The use of potable water during construction should be minimized.</p> <p>23. Separation of grey and black water should be done by the use of dual plumbing line for separation of grey and black water.</p> <p>24. Source of water to be identified.</p> <p>25. Water treatment measures such as filtration, softeners, RO etc should be implemented.</p> <p>26. Low flow fixtures and sensors to be used to promote water conservation.</p> <p>27. Water meters to be installed to monitor consumption of water.</p> <p>28. Water balance table/chart should be prepared.</p>
d.	Waste Water Treatment	<p>29. Sewage treatment plant of capacity capable of treating 100% waste water to be installed on site.</p> <p>30. Tertiary treatment such as dual media filter, activated carbon filter and ozonization/ chlorination to be provided so that the treated water</p>

		<p>characteristics are as per Central Pollution Control Board (CPCB) norms.</p> <p>31. If STP and pump room are installed in basement, adequate ventilation as per NBC air changes norms should be provided.</p> <p>32. Treated waste water to be recycled for flushing and gardening.</p>
e.	Drainage Pattern	<p>33. Excess treated water disposal plan to be submitted.</p> <p>34. Total paved area of the site under parking, roads, paths or any other use should not exceed 25% of the site area or net imperviousness of the site not to exceed the imperviousness factor as prescribed by the NBC 2005 (BIS 2005b), whichever is more stringent.</p> <p>35. The final disposal point for excess treated water discharge will be municipal sewer for areas where sewerage network is present.</p> <p>36. In areas where sewerage network is absent, the excess treated water can be used for agriculture or can be disposed off as per CPCB rules.</p> <p>37. Storm water disposal plan to be submitted.</p> <p>38. The final disposal point for storm water will be municipal storm drain for areas where storm water network is present.</p> <p>39. In areas where storm water network is absent, the storm water surface runoff can be disposed off in nearby natural water streams/ nallas.</p>
f.	Ground Water	<p>40. Hydro-geological survey for ground water analysis shall be submitted.</p> <p>41. Aquifer capacity and Ground water yield shall be determined.</p> <p>42. Rain water harvesting plan shall be submitted indicating the number of recharge pits and bores and total rain water to be harvested.</p> <p>43. Rain water to be harvested and as a safety precaution, rainwater on-line filters be provided as per NBC norms.</p>
g.	Solid Waste Management	<p>A) During construction phase:</p> <p>44. Disposal of muck during construction phase should not create any adverse effect on the neighbouring communities and be disposed taking the necessary precautions for general safety and health aspects of people, only in approved sites with the approval of competent authority. The Rules on the Solid Waste Management including Construction Waste issued by the MoEFCC as amended will be applicable.</p> <p>45. Construction spoils, including bituminous material and other hazardous materials, must not be allowed to contaminate watercourses and the dump sites for such material must be secured so that they should not leach into the ground water.</p> <p>46. Any hazardous waste generated during construction phase, should be disposed off as per applicable rules and norms with necessary approvals of the State Pollution Control Board.</p> <p>47. Miscellaneous site debris such as broken tiles etc shall be used on site for leveling /backfilling purpose.</p> <p>48. Packaged STP /mobile toilets shall be provided for labour camp.</p> <p>49. Polymer bags used for cement and gypsum shall be handed over to authorized recyclers.</p> <p>50. Cardboard boxes and other packaging material will be handed over to authorized recyclers.</p> <p>B) Post construction phase:</p> <p>51. Organic waste compostor (OWC) or Vermiculture pits shall be installed on site for biodegradable waste treatment (capacity calculated at 0.3kg/tenement/day) The manure generated shall be used for landscaping.</p> <p>52. The non-biodegradable waste or e-waste shall be handed over to authorized recyclers.</p> <p>53. STP sludge shall be removed using filter press or centrifuge mechanism. The dried sludge cakes shall be used as manure in landscaping.</p> <p>54. Minimize waste generation, streamline waste segregation, storage, and</p>

disposal; and promote resource recovery from waste.

55. Resource recovery from waste: Employ resource recovery systems for biodegradable waste as per the Solid Waste Management and Handling Rules, 2000 of the MoEFCC. Make arrangements for recycling of waste through local dealers.

56. Use of covering sheets should be done for trucks to prevent dust dispersion from the trucks and washing of tyres when trucks with soil / debris coming on road.

57. Hazardous Waste Management: Products, such as paints, cleaners, oils, batteries, and pesticides that contain potentially hazardous ingredients require special care when being disposed. Improper disposal of household hazardous wastes can include pouring them down the drain, on the ground, into storm sewers, or in some cases putting them out with the trash.

The hazardous wastes from construction and demolition activities are centering oil, formwork oil, tar and tar products (bitumen, felt, waterproofing compounds, etc.), wood dust from treated wood, lead containing products, chemical admixtures, sealants, adhesive solvents, Explosives and related products and equipment used in excavation, acrylics, and silica, etc.

h. Air Quality and Noise Levels.

A) During construction phase:

58. The diesel required for operating DG sets shall be stored in underground tanks and clearance from Chief Controller of Explosives shall be taken, as applicable.

59. Ambient noise levels should conform to residential standards both during day and night as per Noise Pollution (Control and Regulation) Rules, 2000. Incremental pollution loads on the ambient air and noise quality should be closely monitored during construction phase. Adequate measures should be made to reduce ambient air and noise level during construction phase, so as to conform to the stipulated standards by CPCB/ SPCB.

60. Burning of waste to be banned.

61. The construction site DG to be maintained regularly so that the smoke emission and noise levels are as per permissible norms.

62. Regular P.U.C check for all construction machinery coming on site be done.

63. Noise cancellation and insulation devices such as mufflers, barricades etc to be used to avoid noise propagation to adjoining areas.

B) Post construction phase:

64. DG to be regularly maintained so that the smoke emission and noise levels are as per permissible norms. It shall be at least 6 meters away from the boundary.

65. Air quality monitoring to be done quarterly.

66. STP and water pumps, air blowers etc should be installed with noise cancellation devices or suitable acoustical enclosures to be given so that the noise levels as per NBC norms are maintained.

C) During Construction & Operation

67. The provisions of the Air (Prevention and Control of Pollution) Act, 1981 (14 of 1981) and the rules made thereunder be complied for control of noise pollution during construction and operation.

68. Setting up the barriers: National Building Code 2005 suggests that design solutions such as barrier blocks should be used to reduce external LA10 noise levels to at least 60-70 dB (A) at any point 1.0 m from any inward looking façade. Green belts and landscaping could act as an effective means to control noise pollution. In case of railway tracks, a minimum distance of 50m to 70m may be provided between the buildings and the tracks.

i. Energy

69. Appropriate processes and material be used to encourage reduction in carbon foot print.

70. Use of glass be reduced by up-to 40% to reduce the electricity consumption and load on air-conditioning. If necessary, use high quality double glass with special reflective coating in windows.

71. Solar water heater to be provided adequately.

72. Common area lighting should be Solar / LED.
73. Install energy meters to monitor overall consumption, and timer-switch for all common area lighting, and other consumption of measurable energy.
74. Fly ash should be used as building material in the construction as per the provisions of Fly Ash Notification of September, 1999 and amended as on 27th August, 2003 and 3rd November, 2009.
75. Wherever possible recycled materials having low embodied energy be used.
76. Use of light coloured, reflective roofs having an SRI (solar reflectance index) of 50% or more should be promoted. The dark coloured, traditional roofing finishes have SRI varying from 5% to 20%.
77. Optimize use of energy systems in buildings that should maintain a specified indoor environment conducive to the functional requirements of the building by following mandatory compliance measures (for all applicable buildings) as recommended in the Energy Conservation Building Code (ECBC) 2007 of the Bureau of Energy Efficiency, Government of India. The energy systems include air conditioning systems, indoor lighting systems, water heaters, air heaters, and air circulation devices.
78. Use the concept of passive solar design of buildings using architectural design approaches that minimize energy consumption in buildings by integrating conventional energy-efficient devices, such as mechanical and electrical pumps, fans, lighting fixtures, and other equipment, with the passive design elements, such as building orientation, landscaping, efficient building envelope, appropriate fenestration, increased day lighting design, and thermal mass.
79. The building should be oriented optimally based on Sun-path and engineering analysis to curtail excessive solar radiations.
80. Lighting systems should comply with the ECBC 2007 and applicable to interior spaces of buildings, exterior building features, including facades, illuminated roofs, architectural features, entrances, exits, loading docks, and illuminated canopies, exterior building grounds etc. except emergency lighting and lighting in dwelling units.
81. All the point light sources installed in the building for general lighting shall be LEDs or LEDs or equivalent. All the linear light sources installed in the building for general lighting shall be T-5 or at least 4 Star BEE rated TFLs or equivalent. The installed interior lighting power shall not exceed the LPD (Lighting Power Density) value as recommended by ECBC 2007.
82. Automatic Lighting shutoff control be installed: Interior lighting/Exterior Lighting systems shall be equipped with an automatic control device in accordance with ECBC 2007. Occupancy sensors that shall turn the lighting off within 30 minutes of occupant leaving the space. It should also have option for manual turning on lights when the space is occupied. ECBC requires controls in day lit areas that are capable of reducing the light output from luminaries by at least half and Controlling of exterior lighting with photo-controls where lighting can be turned off after a fixed interval.
83. The tapping of renewable sources of energy for lighting, heating, cooling and ventilation needs, deserve special attention. For captive solar power generation, a minimum of 15 percent of sanctioned load is the requirement.
84. Solar photovoltaic (SPV) systems are direct energy conversion systems that convert solar radiation into electric energy. SPV systems should be installed to reduced use of conventional sources of energy. Roof tops of buildings as well as other exposed areas such as of parking shades should be utilized for installation of SPV systems.
85. Hot water requirement in buildings should be met through use of various types of solar water heating systems, viz. flat plate collector; single glazed double glazed; evacuated tube collectors; and Water heating with solar concentrators.
86. The Project Proponent should ensure regular energy audit.
 - i. To validate the predicted energy consumption, thermal comfort, and visual comfort criteria by an energy auditor approved by the BEE, Government of India.

		<p>ii. To ascertain continued safety in the operation of the electrical and mechanical systems of the building through proper maintenance by the owner or the occupants.</p> <p>87. This will be ensured in the contract document by providing for the commissioning of all electrical and mechanical systems by the respective supplier or builder. Moreover, the respective facility management group assigned by the owner or the occupants themselves, will carry out the maintenance facilities.</p> <p>88. Energy conservation measures like installation of CFLs/LEDs for the lighting the areas outside the building should be integral part of the project design and should be in place before project commissioning. Used CFLs and TFLs should be properly collected and disposed off /sent for recycling as per the prevailing guidelines/ rules of the regulatory authority to avoid mercury contamination. Use of solar panels may be done to the extent possible.</p>
j.	Traffic Movement System	89. Width of driveways, parking provision, ramp width and slope to be kept as per local bye laws.
k.	Provisions for Differently able	<p>90. The Project Proponent should provide at least the minimum level of accessibility for persons with disabilities.</p> <ul style="list-style-type: none"> • Ensure accessibility and usability of the facilities in the building by employees, visitors and clients with disabilities. • Ensure access to facilities and services by adopting appropriate site planning to eliminate barriers as per the recommended standards (NBC 2005 [BIS 2005f]). • Layout and designing of interior and exterior facilities as per principles of universal design such as prescribed by the National Building Code of India, building management policies and procedures, provision of auxiliary aids & appliances, and staff training in disability awareness.
l.	Green Belt/Green Cover	<p>91. Provide minimum 1 tree for every 80 sq.mt of plot area.</p> <p>92. Wherever trees are cut or transplanted, compensatory plantation in the ratio of 1:3 to be done in the premise.</p> <p>93. Native species of trees to be planted.</p> <p>94. Vegetation to provide as shading and promote evaporative cooling. In hot and dry climates, evaporative cooling through appropriately sized wet surfaces or fountains have a desirable effect. It should be planned for maximum benefit.</p> <p>95. The project should have detail proposal for tree plantation, landscaping, creation of water bodies etc along with a layout plan to an appropriate scale.</p>
m.	Disaster/Risk Assessment Plan	<p>96. Fire tender movement plan to be submitted.</p> <p>97. Firefighting system to be provided as per the fire NOC.</p> <p>98. Turning radius to be kept as per Fire NoC or as prescribed in the local by-laws.</p> <p>99. Public address system to be installed as per the Fire Safety norms.</p> <p>100. Place of assembly to be indicated.</p>
n.	Socio Economic Impact and CSR	<p>101. Biodegradable and non-biodegradable waste bins to be provided for every household to promote waste segregation at source.</p> <p>102. Importance of environment and various environment drives to be initiated.</p> <p>103. Importance of maintenance of environment infrastructure to be showcased by issuing pamphlets etc.</p> <p>104. Provision for health care, medical kit, crèche, First-Aid room shall be given during construction phase for the construction workers.</p> <p>105. Adequate shelter for resting hours, crèche, clean and potable drinking water to be provided to construction workers.</p> <p>106. All local labour welfare laws must be complied.</p> <p>107. Concerns of the communities being affected by the Project are to be responded on priority, and all possible CSR is to be rendered to make the responses effectively beneficial..</p>

o. Environment Management Plan (EMP)	<p>108. Detailed environment management plan comprising of estimated capital cost and O&M cost for the following environment infrastructure should be submitted:</p> <ul style="list-style-type: none">a. Sewage Treatment Plantb. Landscapingc. Rain Water Harvestingd. Power backup for environment infrastructure.e. Environment Monitoringf. Solid Waste Managementg. Solar and Energy Conservation <p>109. Environment Monitoring Cell with defined functions and responsibility shall be set up and its details be submitted.</p>
--------------------------------------	---

END NOTE:
Industrial Shed*: The word 'industrial shed' implies building (whether RCC or otherwise) which is being used for housing plant and machinery of industrial units and shall include godowns and buildings connected with production related and other associated activities of the unit in the same premise.

Manoj

Page 7 of 7

ANNEXURE-2: RAPID ENVIRONMENTAL ASSESSMENT (REA) CHECKLIST

Instructions:

2. (i) The project team completes this checklist to support the environmental classification of a project. It is to be attached to the environmental categorization form and submitted to the Environment and Safeguards Division (SDES) for endorsement by Director, RSES and for approval by the Chief Compliance Officer.
- (ii) This checklist focuses on environmental issues and concerns. To ensure that social dimensions are adequately considered, refer also to ADB's (a) checklists on involuntary resettlement and Indigenous Peoples; (b) poverty reduction handbook; (c) staff guide to consultation and participation; and (d) gender checklists.
- (iii) Answer the questions assuming the "without mitigation" case. The purpose is to identify potential impacts. Use the "remarks" section to discuss any anticipated mitigation measures.

Country/Project Title:

India (53277): Assam Skill University Project (ASU: Boundary Wall Construction)

Sector Division:

SAHS

Screening Questions	Yes	No	Remarks
A. Project Sitting Is the project area adjacent to or within any of the following areas:			The ASU boundary wall involves construction of boundary wall around ASU Project to secure the site. The ASU Project site is not located within core or buffer zones of national parks, sanctuaries, tiger reserves, or biosphere reserves; nor within 100m from the boundary of protected monuments of archaeological importance.
▪ Underground utilities		√	There are no underground utilities at the proposed site of ASU so no impact on underground utilities due to boundary wall construction.
▪ Cultural heritage site		√	There are no buildings of archaeological and cultural heritage importance close to the site (within 500m distance).
▪ Protected Area		√	There are no protected areas (wildlife park or bird sanctuary) within 35 km aerial distance around the proposed site of ASU.
▪ Wetland		√	There is no wetland within 50km aerial distance around the proposed site of ASU.
▪ Mangrove		√	The proposed site of ASU is away from coastal areas. Hence this is not applicable.
▪ Estuarine		√	The proposed site of ASU is away from coastal areas. Hence this is not applicable.
▪ Buffer zone of protected area		√	The proposed site of ASU is not in the buffer zone of any protected area.
▪ Special area for protecting biodiversity		√	There is no special protected area for biodiversity within 35 km aerial distance from the proposed site of ASU.
▪ Bay		√	The proposed site of ASU is away from the coast. Hence this is not applicable.
B. Potential Environmental Impacts Will the Project cause...			

**Assam Skill University Project
Initial Environmental Examination for Boundary Wall Construction**

Screening Questions	Yes	No	Remarks
▪ Encroachment on historical/cultural areas?		√	There are no historical or cultural areas within 500m from the proposed site of ASU.
▪ Encroachment on precious ecology (e.g. sensitive or protected areas)?		√	The proposed site is located in Mangaldoi, urban areas. Hence it is away from any sensitive or protected areas.
▪ Impacts on the sustainability of associated sanitation and solid waste disposal systems?	√		For wastewater from construction camp, septic tanks will be installed. For the operation phase sanitation facilities constructed at entrance gate (part of boundary wall construction) of ASU campus will be part of sanitation system of ASU. The sanitation system for ASU will be designed accordingly. The septic tanks will be emptied regularly as part of ASU building maintenance schedule. The proper operation and maintenance of sanitation facilities will be ensured through environmental management plan (EMP) implementation. The EMP will be part of contract for the contractor. Solid waste will be disposed of as part of the disposal systems of the local civic body in Mangaldoi.
▪ Dislocation or involuntary resettlement of people?		√	The Boundary wall construction works are to be undertaken at the outer periphery of ASU plot, which is encumbrance-free land. There will be no involuntary resettlement or dislocation of people due to boundary wall construction.
▪ Disproportionate impacts on the poor, women and children, Indigenous Peoples or other vulnerable groups?		√	No negative impacts on the poor, women and children, indigenous peoples, or other vulnerable groups are foreseen due to boundary wall construction. The ASU project as a whole will enhance access to industry-aligned, multidisciplinary, and flexible skills education and training for graduates from higher secondary education, industrial training institutes, polytechnics, engineering colleges, academic colleges and universities, as well as professionals and other working age population, including the poor, women, and indigenous peoples.
▪ Accident risks associated with increased vehicular traffic, leading to loss of life?	√		The ASU site, where boundary wall construction works will be taken up, is not on the national highway or state highway. It will be connected to the national highway through the development of a local road. At present, the local road is earthen road and ends at the site. Traffic near the site is insignificant. During construction, traffic is expected to increase marginally (for material and site staff movement). To minimize any conflict with the local population, vehicles will be driven in a considerate manner. However, to rule out any accident due to the boundary wall construction works on account of vehicular traffic, flagmen will be deployed near the construction site to regulate the traffic. Traffic management plan will be prepared for the construction phase. These mitigation measures will be elaborated in the EMP, which will be part of contract document for the contractor.
▪ Increased noise and air pollution resulting from	√		There will be increase in air and noise pollution due to movement of construction vehicles. The increase is

**Assam Skill University Project
Initial Environmental Examination for Boundary Wall Construction**

Screening Questions	Yes	No	Remarks
increased traffic volume?			<p>expected to be marginal and intermittent in nature because of limited number of construction-related vehicles. To minimize impacts on the local community, mitigation measures (no movement of vehicles at night, mandatory pollution under control certificate, water sprinkling for dust suppression, and regular monitoring of ambient air quality and noise levels) will be elaborated in the EMP.</p> <p>There will be increase in traffic volume owing to the ASU boundary wall construction, so there is a likelihood of some increase in dust and noise levels and vehicular exhaust emissions. To minimize impacts, mitigation measures (water spray on access road and site, and regular monitoring, etc.) will be elaborated in the EMP.</p>
<ul style="list-style-type: none"> ▪ Occupational and community health and safety risks? 	√		<p>The environmental impacts related to the construction of new buildings under the project will be minor in nature and mostly limited to the duration of construction. The impacts will be confined mainly within the construction site. These minor impacts will be mitigated through the EMP. Potential occupational health and safety risks during construction will be addressed by including provisions in the contract documents and implementation of the EMP.</p> <p>In the operation phase, safety risks due to the usage of equipment, machinery, and instruments in the laboratories and workshops of ASU will be mitigated through the formulation of safe operating procedures (SOPs). These SOPs will be developed during installation of equipment and will be displayed at equipment, machinery instruments, practical training tables, platform of laboratories and workshops.</p> <p>For COVID-19 protection during construction and operation phases, COVID-19 health and safety plan will be prepared in accordance with the guidelines issued by the government agencies and in consultation with ADB. This will also be part of contract document to the contractor.</p>
<ul style="list-style-type: none"> ▪ Risks and vulnerabilities related to occupational health and safety due to physical, chemical, biological, and radiological hazards during project construction and operation? 	√		<p>The environmental impact related to the construction of new buildings will be minor in nature and mostly limited to the duration of construction. There will be limited physical, chemical, and biological hazards during construction and operation of ASU. The usage of any radio-active material during construction and operation is not envisaged at present. Adequate provisions will be included in the relevant contract documents to address potential occupational health and safety hazards during the construction.</p> <p>For operation phase, SOPs will be followed to minimize risks and vulnerabilities due to the usage of machinery, equipment and instruments in the laboratories and workshops (including usage of any radio-active materials if unavoidable). These SOPs will be displayed at suitable locations. To minimize COVID-19 related health hazards, COVID-19 health and safety plan will be implemented.</p>
<ul style="list-style-type: none"> ▪ Generation of dust in sensitive areas during construction? 	√		<p>During construction, there will be minor dust generation due to material handling and operation of construction machinery and equipment. This will be</p>

**Assam Skill University Project
Initial Environmental Examination for Boundary Wall Construction**

Screening Questions	Yes	No	Remarks
			controlled through dust suppression measures (e.g., water spray) and proper maintenance of construction equipment and machinery. It will also be ensured that construction equipment and machinery conform to the emission norms laid down by the Central Pollution Control Board. The necessary provisions will be included in the contract document of the contractor.
<ul style="list-style-type: none"> ▪ Requirements for disposal of fill, excavation, and/or spoil materials? 		√	Since boundary wall will be constructed on a green field site, spoil materials will be generated. There will be minor excavations for construction works. The excess earth generated due to these excavations will be utilized in fill works in low-lying portions of the site or any other disposal site as directed by the relevant government agencies. Given that the site is plain land, significant generation of excess excavated earth is not expected. The utilization of excess earth will be suitably included in the contract document.
<ul style="list-style-type: none"> ▪ Noise and vibration due to blasting and other civil works? 		√	During construction, some noise will be generated due to the operation of construction equipment and machinery. Adequate mitigation measures will be stipulated in the EMP. No blasting activity is envisaged during construction. Hence, there will not be any significant shaking or vibrations. Further, no construction works will be carried out during nighttime. There will be periodic ambient noise level monitoring at the construction site as per monitoring plan prepared as part of the EMP.
<ul style="list-style-type: none"> ▪ Long-term impacts on groundwater flows as result of needing to drain the project site prior to construction? 	√		The Assam State has an average annual rainfall of about 1500mm. This intense rainfall causes water logging in plain land. The long-term impact on ground flow is not expected because as part of construction works, an efficient drainage system will be developed. The site having minor water logging will be drained first to expedite boundary wall construction. The drainage construction works will be taken up during ASU campus development.
<ul style="list-style-type: none"> ▪ Long-term impacts on local hydrology as a result of building hard surfaces in or near the building? 		√	The construction of boundary wall along outer limit of ASU plot will not have any impact on hydrology.
<ul style="list-style-type: none"> ▪ Large population influx during project construction and operation that causes increased burden on social infrastructure and services (such as water supply and sanitation systems)? 		√	There will not be large population influx due to boundary wall construction works. As part of construction works, adequate water supply and sanitation systems (as per specified codes) will be developed. Therefore, no burden on social infrastructure and services is anticipated. During construction, the workforce of around 15 is expected. A construction camp with adequate potable water supply and sanitation facilities will be established. Hence, there will not be any burden on social infrastructure and services. Necessary provisions for these requirements will be included in the EMP and contract documents of the contractor.
<ul style="list-style-type: none"> ▪ Social conflicts if workers from other regions or countries are hired? 		√	Preference will be given to locally available labor. The construction activities are relatively small in nature and will take place within the land owned by the Assam Skill Development Mission (the implementing

**Assam Skill University Project
Initial Environmental Examination for Boundary Wall Construction**

Screening Questions	Yes	No	Remarks
			agency) in Mangaldoi. At present, no need to hire workers from other regions or countries is envisaged.
<ul style="list-style-type: none"> ▪ Risks to community safety caused by fire, electric shock, or failure of the buildings safety features during operation? 		√	Since the ASU component pertaining to boundary wall construction so there will not be construction of any building. Hence there will not be any risk to the community safety.
<ul style="list-style-type: none"> ▪ Risks to community health and safety caused by management and disposal of waste? 	√		During construction boundary wall, waste collection and disposal system will be developed and operated by the contractor. The processes being followed will be reviewed and approved by the Assam Skill Development Mission or its appointed representative entity (construction supervision consulting firm). Project management consulting firm will also help the Assam Skill Development Mission in ensuring that the required safety measures are adhered to while managing and disposing of waste.
<ul style="list-style-type: none"> ▪ Community safety risks due to both accidental and natural hazards, especially where the structural elements or components of the project are accessible to members of the affected community or where their failure could result in injury to the community throughout project construction, operation and decommissioning? 	√		All the construction works pertaining to boundary wall will be limited at the ASU plot external limits and plot being in open area away from habitation so no community safety risks are foreseen in construction phase. Further, the boundary wall will be maintained regularly in the operation phase to avoid any accident or hazard pertaining to maintenance. Appropriate traffic safety measures would be deployed during construction phase to minimize accidents with local communities.

A Checklist for Preliminary Climate Risk Screening

Country/Project Title: India (53277):Assam Skill University Project (ASU: Boundary Wall Construction)

Sector: Education

Subsector: Technical and Vocational Education and Training

Division/Department: SAHS

Screening Questions	Score	Remarks ⁴
Location and Design of project Is sitting and/or routing of the project (or its components) likely to be affected by climate conditions including extreme weather related events such as floods, droughts, storms, landslides? Would the project design (e.g. the clearance for bridges) need to consider any hydro-meteorological parameters (e.g., sea-level, peak river flow, reliable water level, peak wind speed etc.)?	0	The proposed ASU site is on plain land, away from river and streams, therefore, boundary wall is not likely to be affected by floods, drought, storms and landslides.
	0	Not Applicable
Materials and Maintenance Would weather, current and likely future climate conditions (e.g. prevailing humidity level, temperature contrast between hot summer days and cold winter days, exposure to wind and humidity hydro-meteorological parameters likely affect the selection of project inputs over the life of project outputs (e.g. construction material)? Would weather, current and likely future climate conditions, and related extreme events likely affect the maintenance (scheduling and cost) of project output(s)?	0	Weather conditions at ASU site do not demand usage of any specific construction material to counteract weather phenomenon.
	0	No, weather conditions at ASU site do not require specific scheduling for maintenance.
Performance of project outputs Would weather/climate conditions and related extreme events likely affect the performance (e.g. annual power production) of project output(s) (e.g. hydro-power generation facilities) throughout their design life time?	0	Not Applicable

Options for answers and corresponding score are provided below:

Response	Score
Not Likely	0
Likely	1
Very Likely	2

⁴ If possible, provide details on the sensitivity of project components to climate conditions, such as how climate parameters are considered in design standards for infrastructure components, how changes in key climate parameters and sea level might affect the sitting/routing of project, the selection of construction material and/or scheduling, performances and/or the maintenance cost/scheduling of project outputs.

Responses when added that provide a score of 0 will be considered low_risk project. If adding all responses will result to a score of 1-4 and that no score of 2 was given to any single response, the project will be assigned a medium risk category. A total score of 5 or more (which include providing a score of 1 in all responses) or a 2 in any single response will be categorized as high risk project.

Result of Initial Screening (Low, Medium, High): Low Risk

Other Comments: None

Prepared by:

**ANNEXURE-3: LAND RECORDS CERTIFIED BY THE REVENUE DEPARTMENT
OFFICIALS SHOWING GOA OWNERSHIP**

Assam Schedule XXXVII Form No. 39

Chitha for Surveyed Villages / জৰীপ হোৱা গাঁৱৰ চিঠা

জিলা নং	মহকুমা/মহলগৈ (নং)	চক্ৰ মহলগৈ
মৌজা নং	লট-লট নং	পত্ৰ নং/গেৰিমাৰীচাপনী

দাগ নং	মাটিৰ শ্ৰেণী		কালি (বি.ক.লে)	পত্ৰ নং আৰু প্ৰকাৰ	বাজ্জটকা	স্বত্বীয় কৰ(টকা)
	কৃষি	অকৃষি				
১	২		৩	৪	৫	৬
২২/১৬৫১	বিশেষ ফৰিং		১০০-০-০	০, চৰকাৰী	০.০০	০.০০

পত্ৰ/দাৰৰ নাম পিতাৰ নাম আৰু ঠিকনা	নামজাৰী হবলগীয়া দফলদাৰৰ নাম, পিতাৰ নাম, ঠিকনা	স্বত্ব/ আধিকাৰ নাম, পিতাৰ নাম, ঠিকনা	স্বত্ব/ প্ৰকাৰ/ খতিয়ন নং, খাজানা বা ফছলৰ বিবিধ	উল্লেখ নাম, পিতাৰ নাম, ঠিকনা	বছৰ	বেফছলী মাটিৰ কালি		ফছলী মাটিৰ কালি				ফছল পৰ নাম	ফছল বি. ক. লে	একাধিক ফছলী মাটিৰ কালি	ফছল পৰ নাম আৰু সংখ্যা	মন্তব্য
						মাটি কেনেদৰে ব্যৱহৃত	কালি (বি. ক. লে)	ক'ৰপৰা পানী পায়	ফছলৰ নাম	কালি (বি. ক. লে)	একাধিক ফছলী মাটিৰ কালি					
৭	৮	৯	১০	১১	১২ ১৩ ১৪	১৫ ১৬ ১৭	১৮ ১৯ ২০	২১ ২২ ২৩	২৪ ২৫ ২৬	২৭ ২৮ ২৯	৩০	৩১	৩২	৩৩	৩৪	৩৫
১) চৰকাৰী (অভিভাৱক চৰকাৰ) 100 B-0 K-0 L ঠিকনা (.)					2020 2019 2018											<p>মন্তব্য</p> <p>১) মৰং জিলাৰ উপায়ুক্ত মহোদয়ৰ 12-08-2020 জৰিখৰ DMS/89/2017/155 নং চিঠি মৰ্মে ও অসম চৰকাৰৰ বাজুই ও স্বত্বাধাৰ প্ৰশমন বিভাগৰ উপ সচিব মহোদয়ৰ 05-08-2020 জৰিখৰ R55.53336/2018/104 আৰু 10-08-2020 জৰিখৰ ECF No.53336/2018/107 নং হুকুম মৰ্মে বক্তা মাটি মৌজাৰ গেৰিমাৰি চাপৰি গৱৰ 22 নং ভি জি আৰ দাসৰ অংশ 100 বিঘা জমি ছিল জিটি, মৰং নামত সংৰক্ষণ মুক্ত কৰি পৃথক 1651 নং বিচাপে নথি সংশোধন কৰা হল।----জয়প্ৰকাশ দাস</p>

Print this page Close this window



GOVERNMENT OF ASSAM
OFFICE OF THE CIRCLE OFFICER: MANGALDAI REVENUE CIRCLE
MANGALDAI : DARRANG

No.MRC- 12/2018/9165

Dtd. 12/10/2020

Land Holding Certificate

This is to certify that a plot of land measuring 100 Bighas covered by Dag No.22 at village Gerimari Chapori under Rangamati Mouza under Mangaldai Revenue Circle is recorded in the name of Skill City, Darrang in pursuance of Govt. order ECF No.53336/2018/26 Dated Dispur, the 13th January,2020.

Schedule of the Land:

Dag No.	Mouza	Village	Area	Remarks
22	Rangamati	Gerimari Chapori	100 Bighas	Recorded in the name of Skill City, Darrang in the Field index.

Circle Officer,
Mangaldai Revenue Circle
Mangaldai, Darrang, Assam



GOVT. OF ASSAM
OFFICE OF THE DEPUTY COMMISSIONER :: DARRANG :: MANGALDAI
(LAND SETTLEMENT BRANCH)

Tel : 03713 222135 :: Fax - 03713 222800, Email : dc-darrang@nic.in. Website : <http://www.darrang.nic.in>

187

No. DRS. 85/2017/187

Dated Mangaldai, the 8th January, 2021

To,

The Mission Director,
Assam Skill Development Mission,
Katabari, NH-37, Guwahati-781035

Sub : Allotment of land in favour of Assam Skill University.

Sir,

With reference to the subject cited above and as per discussion held on 05.01.2021 in the office of the undersigned, I have the honour to inform you that in continuation to earlier allotment of 100 Bighas of land in favour of Assam Skill University vide Govt. letter No. 53336/2018/106 dated 31.07.2020, the Sub-Divisional Land Advisory Committee held on 11.12.2020 has recommended another 150 Bighas of land in favour of Assam Skill University adjacent to earlier allotment in the same village Gerimari consisting of Dag No. 28, 29, 30, 31, 32, 33, 34, 35, 36, 165, 166, 167, 168, 169, 170, 171, 172, 173, 174, 175, 176, 177, 178, 179, 180, 181, 182, 201, 202, 203, 204, 205, 206, 207 and 208 under Rangamati Mouza of Mangaldai Revenue Circle.

This is for favour of your information and necessary action.

Enclo : As stated above.

Yours faithfully,

Deputy Commissioner
Darrang, Mangaldai

ANNEXURE-4: SAMPLE TRAFFIC MANAGEMENT PLAN

A. Principles

1. Since the scale of construction work for the boundary wall is relatively small, there will not be any major or prolonged disruption of local traffic. Nevertheless, it is good to prepare a traffic management plan (TMP) to minimize and avoid public inconvenience to the extent feasible. This indicative TMP will ensure the safety of all the road users along the work zone and minimize public inconvenience. It addresses the following issues:

- (i) The safety of pedestrians, bicyclists, and motorists travelling close to the construction zone;
- (ii) Protection of work crews from hazards associated with vehicle and equipment movement;
- (iii) Avoiding traffic congestion and
- (iv) Maintenance of access to adjoining properties.

B. Operating Policies for TMP

2. The following principles will help to promote safe and efficient movement for all road users (motorists, bicyclists, and pedestrians, including persons with disabilities) through and around work zones while reasonably protecting workers and equipment.

- (i) Make traffic safety and temporary traffic control an integral and high-priority element of every project from planning through design, construction, and maintenance.
- (ii) Inhibit traffic movement as little as possible.
- (iii) Provide clear and positive guidance to drivers, bicyclists, and pedestrians as they approach and travel through the temporary traffic control zone.
- (iv) Inspect traffic control elements routinely, both day and night, and make modifications when necessary.
- (v) Pay increased attention to roadside safety in the vicinity of temporary traffic control zones.
- (vi) Keep the public well informed.
- (vii) Make appropriate accommodation for abutting property owners, residents, businesses, emergency services, railroads, commercial vehicles, and transit operations.

C. Analyze the impact due to street closure, if required

3. A final decision to close a particular street and divert the traffic should involve the following steps:

- (i) approval from the PMU site team and local administration to use alternative local streets as detours;
- (ii) consultation with businesses, community members, traffic police, PWD, etc, regarding the mitigation measures necessary at the detours where the road is diverted during the construction;
- (iii) determining of the maximum number of days allowed for road closure, and incorporation of such provisions into the contract documents;
- (iv) determining if additional traffic control or temporary improvements are needed along the detour route;
- (v) considering how access will be provided to the worksite;
- (vi) contacting emergency service, school officials, and transit authorities to determine if there is any effect on their operations; and

- (vii) Developing a notification program to keep the public informed. As part of this program, the public should be advised of alternate routes that commuters can take or will have to take as result of the traffic diversion.

4. If full road-closure of certain streets within the area is not feasible due to inadequate capacity of the detour streets or public opposition, then full closure can be restricted to weekends with the construction commencing on Saturday night and ending on Monday morning prior to the morning rush hour traffic.

Figure: Policy Steps for the TMP

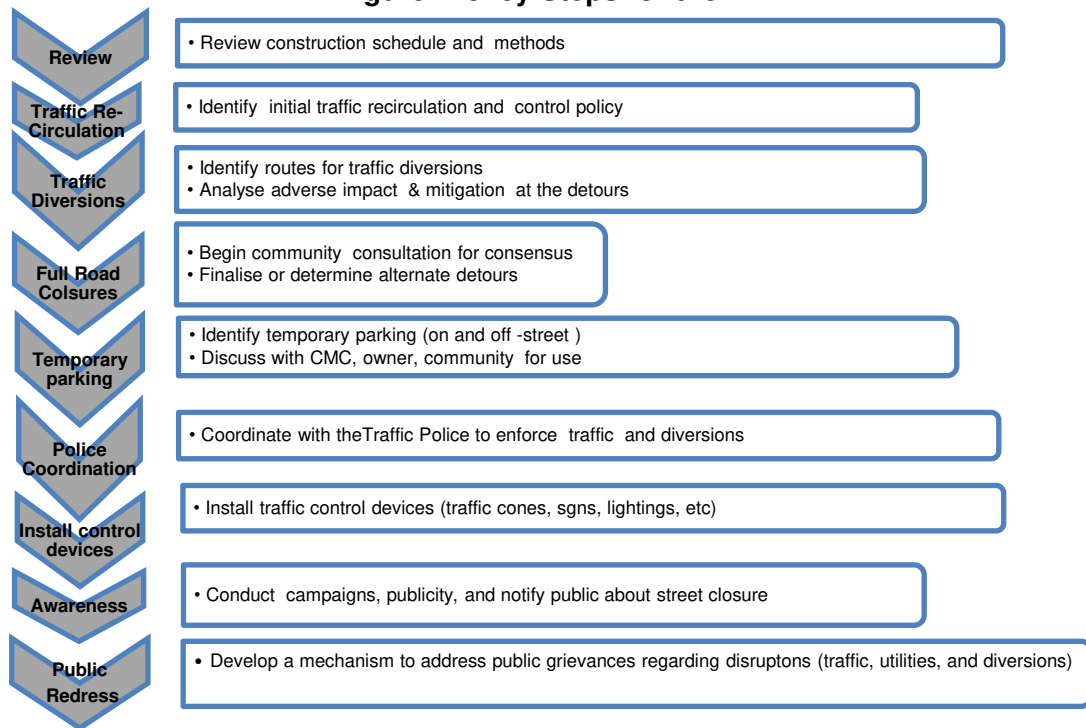

D. Public awareness and notifications

5. The PMU site team and the contractor will issue timely notifications to inform the public about the following issues:

- (i) Road blockages and alternative routes along with the duration (as applicable)
- (ii) Traffic control devices placed around the construction zones (signs, traffic cones, barriers, etc.);
- (iii) Reduced speed limits to be enforced at the work zones and traffic diversions.

8. It may be necessary to conduct an awareness campaign on road safety during construction. It will target relevant groups i.e. children, adults, and drivers. Therefore, these campaigns will be conducted in schools and community centers. In addition, the project will publish a brochure for public information. These brochures will be widely circulated around the area and will also be available at the site office. The text of the brochure should be concise to be effective, with a lot of graphics. It will serve the following purpose:

- (i) Explain why the brochure was prepared, along with a brief description of the project;
- (ii) Advise the public to expect the unexpected;

- (iii) Educate the public about the various traffic control devices and safety measures adopted at the work zones;
- (iv) Educate the public about the safe road user behaviour to emulate at the work zones;
- (v) Tell the public how to stay informed or where to inquire about road safety issues at the work zones (name, telephone, mobile number of the contact person; and
- (vi) Indicate the office hours of relevant offices.

E. Vehicle Maintenance and Safety

10. A vehicle maintenance and safety program shall be implemented by the construction contractor. The contractor should ensure that all the vehicles are in proper running condition and comply with roadworthy and meet certification standards of GoA. All vehicles should be in good condition and meet the pollution standards of GoI and GoA. The drivers will follow the special code of conduct and road safety rules of GoA. They will ensure that all loads are covered and secured. The vehicle cleaning and maintenance will not be taken up at site.

F. Install traffic control devices at the work zones and traffic diversion routes

10. The purpose of installing traffic control devices at the work zones is to delineate these areas to warn, inform, and direct the road users about a hazard ahead, and to protect them as well as the workers. As proper delineation is the key for achieving the above objective, it is important to install good traffic signs at the work zones. The following traffic control devices will be used in work zones:

- Signs
- Pavement Markings
- Channelizing Devices
- Arrow Panels
- Warning Lights

11. Procedures for installing traffic control devices at any work zone vary depending on road configuration, location of the work, construction activity, duration, traffic speed and volume, and pedestrian traffic. Work will take place along major roads, and the minor internal roads. As such, the traffic volume and road geometry vary. However, regardless of where the construction takes place, all the work zones should be cordoned off, and traffic shifted away at least with traffic cones, barricades, and temporary signs (temporary “STOP” and “GO”).

12. The work zone should take into consideration, the space required for a buffer zone between the workers and the traffic (lateral and longitudinal) and the transition space required for delineation, as applicable. For the works, a 30 cm clearance between the traffic and the temporary STOP and GO signs should be provided. In addition, at least 60 cm is necessary to install the temporary traffic signs and cones.

13. Traffic police should regulate traffic away from the work zone and enforce the traffic diversion result from full street closure in certain areas during construction. Flaggers or personnel should be equipped with reflective jackets at all times and have traffic control batons (preferably the LED type) for regulating the traffic.

14. In addition to the delineation devices, all the construction workers should wear fluorescent safety vests and helmets in order to be visible to the motorists at all times. There should be provision for lighting beacons and illumination for night constructions. The PMU site team and contractor will coordinate with the local administration and traffic police

regarding the traffic signs, detour, and any other matters related to traffic. The contractor will prepare the traffic management plan in detail and submit it along with the EMP for the final approval.

ANNEXURE-5: PHOTOGRAPHS AND ATTENDANCESHEETSOF CONSULTATIONS

A. Photographs



Discussion with Stakeholders at Site



Another View of Discussion with Locals at Site



Discussion with locals near Site



View of Stakeholder Consultations at Darrang Deputy Commissioner Office

B. Attendance Sheets

Project 53388 IND: Assam Skill University Project

Stakeholder Consultations

Dated: _____ Location: _____

Sl. No.	Name	Organization	Phone Number	Signature
1	DILIP K...	J.C.	9435054171	[Signature]
2				
3	Nobanjyoti opha	ADC, Darrang	94351-61015	[Signature]
4	Ponlag Ks. Decha	ADC, Dima	9435119326	[Signature]
5	Kumar Sujat...	A.D.C., Darrang	76378/55813	[Signature]
6	Deep J. Baishya	ASDM, PHU	7896515595	[Signature]
7	S			
8	Pinku Choudhury	AsPM, ASPH SH & CB	8252066979	[Signature]
9	SUJATMULLICK	GESI, Consultant	9830306275	[Signature]
10	YASHPAL MALIK.	F.A. Coordinator Consultant, ADB	9015040458	Yashpal malik
11	Nayan d. Patra	CO, Mangabai	7086521731	[Signature]
12	Rajashree Anil	HORIZON, NGO Gen. Secy.	7002230788	[Signature] 12/11/2020
13	Madhuri Borah	D.S.W.O.	94350.35799	[Signature]
14	Girendakalita	BDO, Pub MUP	7002538244	[Signature]
15	Rekha Biswas.	President G.P.	6002516502	[Signature] 12/11/20
16	Gajendra Beka	Gaonbureh	9957678431	[Signature]

ATTENDENCE SHEET FOR THE MEETING HELD ON 12/11/2020
CONFERENCE HALL OF DEPUTY COMMISSIONER : DARRANG AT 12 P.M

Sl. No.	Name	Designation	Mobile	Signature
	Kumar Sujal Bora	A.D.C., Darrang	76378/55813	
	Pankaj K. Debn	ADC, Darrang	9435119326	
	Kabirjyoti Ojha	ADC, Darrang	94351-61015	
	Shreenidhi Das Bora	Environment Specialist - Consult ADD	9811226458	
	N. Debroy Singh	SPM-SMLCB	7002017676	
	YASHPAL MALIK	TA COORDINATOR Consult - ADD	9015040458	Yashpal malik
	Sujata Mukherjee	GESI Consultant ADD	9830304275	
	Pinku Choudhury	ASPH, SH&CB ASDH	8752066979	
	Deep Jyoti Borthya	ASUP, PMU team	7896515595	
	Dipankar Borman	SPM - ASDM	9886099104	
	MRIDUL BORUAH	AE, PCBA, RLO, TEZPUR	9101421844	mbe
	Gautanga K. Das	Dist. Labour officer	9435151181	
	Madhuri Behera	District social welfare officer	94350-35773	
	Gobinda Kalita	BDO, Sub Mangaldai	7002538244	
	Rekha Biswas.	President G.P.	6002516502	
	Gajendra Seta	Gasambhar	9957078431	
	Rajashree Sinl.	Gen Secy. HORIZON NGO.	7002230788	
	Nayan J. Pathak	CO, Mangaldai	7086521731	

Assam Skill University Project

Name	Organization	Phone	Signature
Jatindra Kalita		97399910560	
Kaushik Anandam		7577058548	
সৌভাগ্যনাথ মল্লিক		9401467318	
পূর্ণিমা - ৬৬৭ ২১১			
সুপ্রিয় হালদা		81350000	
Karakiyoti Saitia		9101647560	
Anima Beka	Gesimari	7002359217	
Kushal Kalita		9864741475	
পূৰ্ণিমা নাথ		8071287280	
Surentra Bora		9859368447	
Hidera Hidera		7577097359	
নিসি মল্লিক		9356243708	
Chiranjeev Debnath (Chiranjeev)		9957078431	
Pwipen Bahariak		8721048353	